

# Knürr Mobile Equipment Carriers

Universal Cart Systems

Ergonomic, Modular, Future-Proof



# Knürr Mobile Equipment Carriers

Mobility In Practice	2
Knürr EliMobil®	4
Knürr DacoMobile®	11
Knürr SynergyCart®	21
Knürr Cabinet Cart – Rollo	29
Knürr Cabinet Cart	31
Knürr MetraMobil®	37
Accessories	44
Individual solution	51

Mobility In Practice

## Modular & Industrial Solutions

Whether it be the workshop area, electronics lab, in health care applications or in office environment, our extensive standard range provides diverse solutions for the safe and secure mobility of valuable equipment. Our modular designs enable versatile cart configurations, immediately or at any time later on.

For demanding ESD environments Knürr provides various cart systems – ranging from robust transport trolleys through to the fully equipped measurements and diagnostics cart.

Ergonomic details also simplify daily tasks in a wide range of environments.

An extensive range of accessories supplements Knürr's mobile equipment carriers as requested by the customer: Flat screen holders, ESD castors, isolating transformers and leakage detectors, cable routing elements and all kinds of accessories for the medical sector.



MOB20030



MOB 20026

SYN20024

MET 20000

## Knürr EliMobil® Strong points



BIL00071



BIL00072



BIL00107

### ■ Aesthetics

- Modern and slim look with dynamic shapes
- Extrusions and die-cast rockers in modern design with narrow crosspiece
- Side panels of the shelves dynamically shaped
- Cable ducts are aesthetic and space-savily integrated into the extrusion

### ■ Functionality

- High EMC safety with separate cable routing of mains and data cables
- Storage space in the crosspiece for socket strips and excess cables
- Space-saving with optional use of surface areas with 2 basic widths\* (450 mm and 550 mm)  
\*useable internal dimension between the extrusions
- Worktop can be loaded up to 300 N  
(overall load rating of the trolley: up to 1800 N)
- Distributed load drawer extension up to 100 N

### ■ Variability

- Numerous individual models possible
- All modules can be combined and mounted in the easiest possible way
- Individual configuration with adjustment of the installation components at 25 mm intervals
- Simple and quick adjustment without special tools

### ■ Convenience

- Easy to clean with coated surfaces
- All surfaces are corrosion-free, impact and scratch-proof and acid and disinfection agent-resistant
- Vibration-free and noiseless transport with special rubber smooth-running castors Ø 100 mm



BIL20011



BIL00151

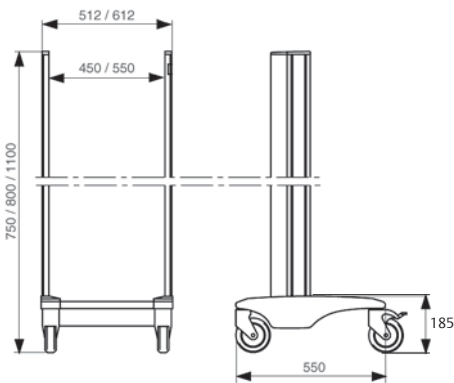

BIL00237



BIL20010

## Knürr EliMobil® System Components

### Technical data

- Modules can be installed at increments of 25 mm

#### ■ Maximum static load rating

- Per basic frame: 1800 N
- Per castor: 750 N
- Surface load per worktop: 300 N

#### ■ Material

Basic rack consists of:  
 - Extrusions: extruded aluminium  
 - Rockers: die-cast aluminium  
 - Crosspiece: sheet steel  
 Worktops: sheet steel/plastic  
 Storage shelf, storage tray, drawer module: sheet steel

#### ■ Finish

- Metal parts: powder-coated texture
- Plastic parts: coated texture

#### ■ Color combinations

##### Final digit of order number.2:

- Basic frame: RAL 7035 light-grey
- Plastic caps: RAL 5003 sapphire blue
- Castors: RAL 9011, graphite black

#### ■ How supplied

Fully assembled

## Knürr EliMobil® Laptop cart

#### ■ Dimensions

Height, 800  
 Overall width, 512 mm  
 Useable width, 450 mm  
 Depth, 550 mm

#### ■ Supply schedule

1 Basic frame  
 1 Worktop with handle  
 1 Drawer unit  
 Division 3 OU  
 1 Storage tray

#### ■ Material

Extrusions: aluminium  
 Worktops: sheet steel/plastic

#### ■ Color combinations

RAL 7035 light-grey/  
 RAL 5003 sapphire blue

#### ■ Castors

RAL 9011, graphite black

#### ■ How supplied

Fully assembled

W	H	D	w	d	Order no.	UP
512	800	550	450	427	00.306.447.2	1 unit

Dimensions in mm: W = Width  
 H = Height  
 D = Depth  
 h = Installation height  
 d = Useful depth  
 L = Length

HU = Standard height unit, 1 HU = 44.45 mm  
 19" = 482.6 mm, (ideal for 19" components in acc. with DIN 41494)  
 UP = Unit of packaging  
 kg = Weight

Conversion: 1 inch = 25.4 mm

Replace „x“ with the number of your color choice



BIL00216

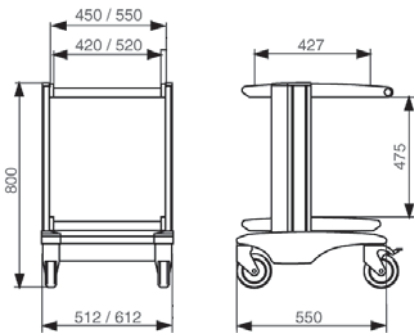

BIL00205



BIL00217

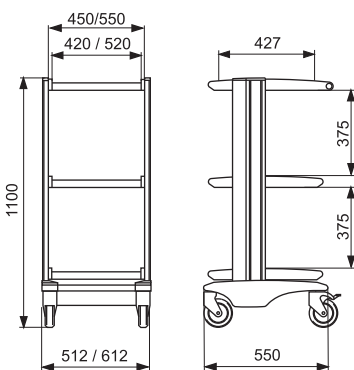

BIL00206

## Knürr EliMobil® PC 3

### ■ Dimensions

Height 800 mm  
Overall width, 512 or 612 mm  
Useable width, 450 or 550 mm  
Depth, 550 mm

### ■ Supply schedule

1 Basic frame  
1 Worktop with handle  
1 Worktop

### ■ Material

Extrusions: aluminium  
Worktops: sheet steel/plastic

### ■ Color combinations

RAL 7035 light-grey/  
RAL 5003 sapphire blue

### ■ Castors

RAL 9011, graphite black

### ■ How supplied

Fully assembled

W	H	D	d	w	Order no.	UP
512	800	550	427	450	00.306.424.2	1 unit
612	800	550	427	550	00.306.425.2	1 unit



## Knürr EliMobil® PC 4

### ■ Dimensions

Height, 1,100 mm  
Overall width, 512 or 612 mm  
Useable width, 450 or 550 mm  
Depth, 550 mm

### ■ Supply schedule

1 Basic frame  
1 Worktop with handle  
2 Worktops

### ■ Material

Extrusions: aluminium  
Worktops: sheet steel/plastic

### ■ Color combinations

RAL 7035 light-grey/  
RAL 5003 sapphire blue

### ■ Castors

RAL 9011, graphite black

### ■ How supplied

Fully assembled

W	H	D	d	w	Order no.	UP
512	1100	550	427	450	00.306.428.2	1 unit
612	1100	550	427	550	00.306.429.2	1 unit





BIL00224

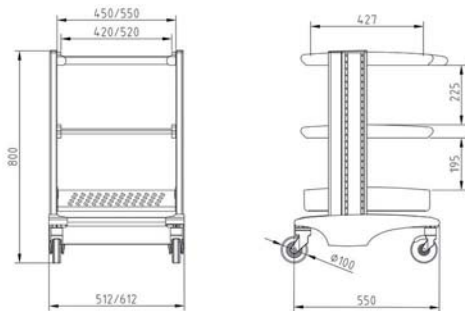

BIL00225

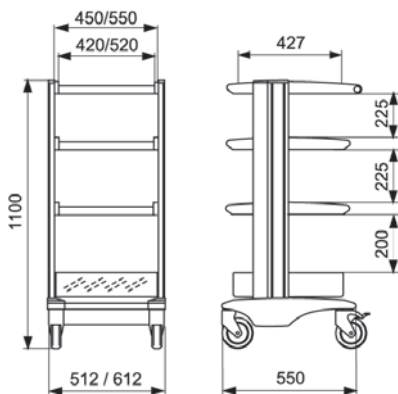

BIL00208

Dimensions in mm: W = Width  
H = Height  
D = Depth  
h = Installation height  
d = Useful depth  
L = Length

HU = Standard height unit, 1 HU = 44.45 mm  
19" = 482.6 mm, (ideal for 19" components in acc. with DIN 41494)  
UP = Unit of packaging  
kg = Weight

Conversion: 1 inch = 25.4 mm

Replace „x“ with the number of your color choice

**P** = assemble to order (shipped within 10 working days)

Caution: In case of larger orders, delivery times may increase.

## Knürr EliMobil® Labor 3

### ■ Dimensions

Height, 800  
Overall width, 512 or 612 mm  
Useable width, 450 or 550 mm  
Depth, 550 mm

### ■ Supply schedule

1 Basic frame  
1 Worktop with handle  
1 Worktop  
1 Storage tray

### ■ Material

Extrusions: aluminium  
Worktops: sheet steel/plastic

### ■ Color combinations

RAL 7035 light-grey/  
RAL 5003 sapphire blue

### ■ Castors

RAL 9011, graphite black

### ■ How supplied

Fully assembled

W	H	D	d	w	Order no.	UP
512	800	550	427	450	00.306.432.2	1 unit
612	800	550	427	550	00.306.433.2	1 unit

## Knürr EliMobil® Labor 4

### ■ Dimensions

Height, 1,100 mm  
Overall width, 512 or 612 mm  
Useable width, 450 or 550 mm  
Depth, 550 mm

### ■ Supply schedule

1 Basic frame  
1 Worktop with handle  
2 Worktops  
1 Storage tray

### ■ Material

Extrusions: aluminium  
Worktops: sheet steel/plastic

### ■ Color combinations

RAL 7035 light-grey/  
RAL 5003 sapphire blue

### ■ Castors

RAL 9011, graphite black

### ■ How supplied

Fully assembled

W	H	D	d	w	Order no.	UP
512	1100	550	427	450	00.306.436.2	1 unit
612	1100	550	427	550	00.306.437.2	1 unit



## Knürr EliMobil® Labor 5

### ■ Dimensions

Height, 800  
Overall width, 512 or 612 mm  
Useable width, 450 or 550 mm  
Depth, 550 mm

### ■ Supply schedule

1 Basic frame  
1 Worktop with handle  
1 Drawer module  
Division: 3 OU  
1 Worktop

### ■ Material

Extrusions: aluminium  
Worktops: sheet steel/plastic

### ■ Color combinations

RAL 7035 light-grey/  
RAL 5003 sapphire blue

### ■ Castors

RAL 9011, graphite black

### ■ How supplied

Fully assembled

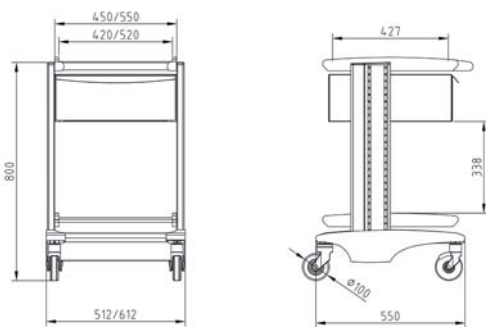

W	H	D	d	w	Order no.	UP
512	800	550	427	450	00.306.448.2	1 unit
612	800	550	427	550	00.306.449.2	1 unit



## Knürr EliMobil® Labor 7

### ■ Dimensions

Height, 1,100 mm  
Overall width, 512 or 612 mm  
Useable width, 450 or 550 mm  
Depth, 550 mm

### ■ Supply schedule

1 Basic frame  
1 Worktop with handle  
1 Drawer module, height 150 mm  
1 Worktop  
1 Storage tray

### ■ Material

Extrusions: aluminium  
Worktops: sheet steel/plastic

### ■ Color combinations

RAL 7035 light-grey/  
RAL 5003 sapphire blue

### ■ Castors

RAL 9011, graphite black

### ■ How supplied

Fully assembled

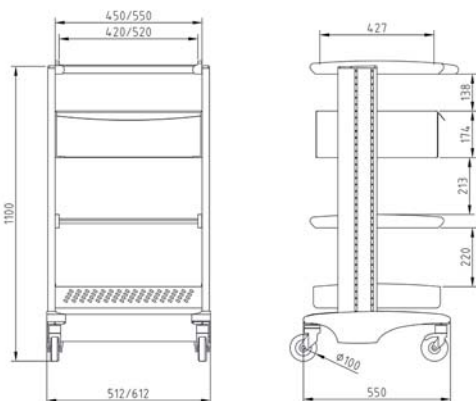

W	H	D	d	w	Order no.	UP
512	1100	550	427	450	00.306.541.2	1 unit
512	1100	550	427	550	00.306.542.2	1 unit







BIL00134

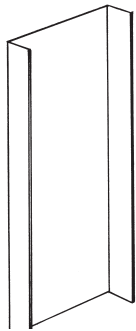

BIL00224



BIL00169

## Knürr EliMobil® Basic Rack

- Modules can be installed at increments of 25 mm

### Maximum static load rating

- Per basic rack: 1,800 N
- Per castor: 750 N

### Material

- Extrusions: extruded aluminum
- Rockers: die-cast aluminum
- Crosspiece: sheet steel

### Finish

Metal parts: powder-coated texture

### Color combinations

- Basic rack: RAL 7035, light gray
- Castors: RAL 9011, graphite black

W	H	D	w	Order no.	UP
512	750	550	450	00.306.621.2	1 unit
512	800	550	450	00.306.631.2	1 unit
512	1100	550	450	00.306.641.2	1 unit
612	750	550	550	00.306.622.2	1 unit
612	800	550	550	00.306.632.2	1 unit
612	1100	550	550	00.306.642.2	1 unit



## Knürr EliMobil® Rear Panel

### Material

Sheet steel, powder-coated

### Color

RAL 7035, light gray, antistatic

W	H	D	w	Order no.	UP
	750	125	450	00.306.850.1	1 unit
	800	125	450	00.306.851.1	1 unit
	1100	125	450	00.306.852.1	1 unit
	750	125	550	00.306.853.1	1 unit
	800	125	550	00.306.854.1	1 unit
	1100	125	550	00.306.855.1	1 unit

## Knürr EliMobil® Worktop

### Material

Side panels – plastic  
Covers – sheet steel, powder-coated  
Handle – aluminum, powder-coated

### Color

RAL 7035, light gray

W	H	D	w	d	Model	Order no.	UP
		475	450	427	without handle	00.306.761.1	1 unit
		475	550	427	without handle	00.306.762.1	1 unit
		475	450	427	with handle	00.306.751.1	1 unit
		475	550	427	with handle	00.306.752.1	1 unit



## Knürr EliMobil® Storage Shelf

### Material

Sheet steel, powder-coated

### Color

RAL 7035, light gray

W	H	D	w	Model	Order no.	UP
	17	475	450	fixed	00.306.773.1	1 unit
	17	475	550	fixed	00.306.774.1	1 unit
	17	475	450	tilt	00.306.775.1	1 unit
	17	475	550	tilt	00.306.776.1	1 unit

Dimensions in mm: W = Width  
H = Height  
D = Depth  
h = Installation height  
d = Useful depth  
L = Length

HU = Standard height unit, 1 HU = 44.45 mm  
19" = 482.6 mm, (ideal for 19" components in acc. with DIN 41494)  
UP = Unit of packaging  
kg = Weight

Conversion: 1 inch = 25.4 mm

Replace „x“ with the number of your color choice

**P** = assemble to order (shipped within 10 working days)

Caution: In case of larger orders, delivery times may increase.



BIL00225

## Knürr EliMobil® Storage Tray

**Material**  
Sheet steel, powder-coated

**Color**  
RAL 7035, light gray

W	H	D	w	Order no.	UP
91	475	450		00.306.781.1	1 unit
91	475	550		00.306.782.1	1 unit



BIL20010

## Knürr EliMobil® Drawer Module

**Material**  
Sheet steel, powder-coated

**Color**  
RAL 7035, light gray

W	Model	Order no.	UP
450	3 OU	00.306.714.2	1 unit
550	3 OU	00.306.715.2	1 unit



BIL00179

Photo similar

## Knürr EliMobil® Keyboard Extension Open

- With mouse table – moves to the left/right

**Color**  
RAL 7035, light gray

**Material**  
Sheet steel, powder-coated

W	H	D	Order no.	UP
450	55	455	00.306.725.1	1 unit
550	55	455	00.306.730.1	1 unit

\*\* External dimension same as useable surface



BIL00151

## Knürr EliMobil® Castor Set

**Load capacity**  
750 N per castor Ø 100 mm

**Supply schedule**  
4 smooth-running castors  
2 with snib

**Color**  
RAL 9011, graphite black

ESD	Order no.	UP
	00.306.965.9	1 Stk
	00.128.980.9	1 Stk

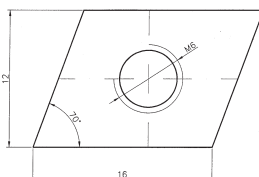

## Knürr EliMobil® Sliding Nut, M6

- For mounting components or accessories on the outside of the extrusion

**Supply schedule**  
20 sliding nuts

W	H	D	Order no.	UP
12	4	16	00.306.970.8	1 unit

## Knürr DacoMobile® Strong points



MOB00274



MOB20095



MOB20096



MOB20053

### ■ Stability

- Total load rating of up to 2100 N
- Worktops each with up to 800 N load rating
- High stability with low-lying centre of gravity
- Distributed load drawer extension up to 200 N
- Torsional strength with stable aluminium extrusions on die-cast aluminium stabilizers and cross-piece of sheet steel
- Optimal stability for equipment set up in the trolley with raised edges all around the worktop

### ■ Convenience

- Optimised operation with additional module components, such as
  - Cable duct
  - Rear panel
  - Euro mains distributor
  - Master switch
  - Socket strip
- Ergonomically optimal adjustment with
  - Keyboard extension with side mouse table
  - Pull-out shelves
- Effortless management of obstacles and uneven floors with Ø 125 mm large smooth-running castors
- Positioning with 2 lockable castors
- No marks and scratches on the doors, panels and fittings due to the integrated plastic bumper cap

### ■ Variability

- Standard and ESD model components
- Modular designs enable numerous individual models
- Versatile applications ranging from the simple storage trolley to the complex medical trolley
- Simple and quick adjustment without special tools

Dimensions in mm: W = Width  
H = Height  
D = Depth  
h = Installation height  
d = Useful depth  
L = Length

HU = Standard height unit, 1 HU = 44.45 mm  
19" = 482.6 mm, (ideal for 19" components in acc. with DIN 41494)  
UP = Unit of packaging  
kg = Weight

Conversion: 1 inch = 25.4 mm  
Replace „x“ with the number of your color choice

**P** = assemble to order (shipped within 10 working days)

Caution: In case of larger orders, delivery times may increase.

## Knürr DacoMobile® system components

### Technical data



MOB20051

- Modules can be installed in 50 mm increments in height
- Smooth-running castors, Ø 125 mm, two with stoppers

#### Material

Basic rack consists of:

- Extrusions: extruded aluminum
- Runners: die-cast aluminum
- Crosspiece: sheet steel

Worktop:

sheet steel

Other modules: combination of sheet steel with laminated particle board, or sheet steel.

#### Finish

Metal parts: powder-coated texture

Laminated sheet: fine-textured

#### Color

Extrusions, runners, castors: RAL 5003, sapphire blue or RAL 7021 ESD or RAL 7035, light gray

Modules:

RAL 7035, light gray

ESD castors: black

#### Maximum static load rating

Per basic rack: 2,100 N

Per castor: 750 N

Surface load per worktop: up to 800 N

#### How supplied

Fully assembled

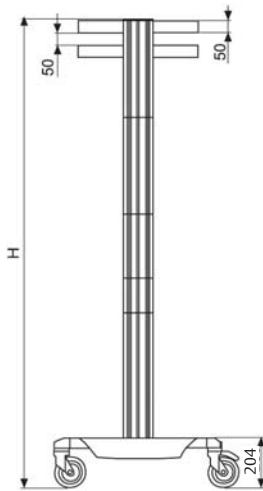

MOB20035

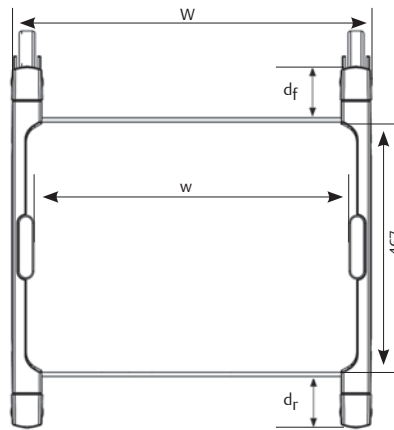

MOB20076

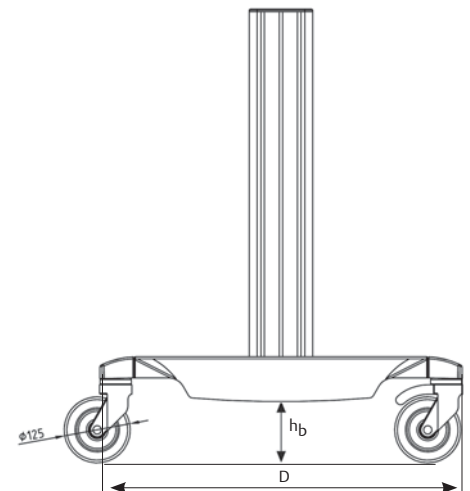

MOB20077

Installation position of the Knürr DacoMobile® elements in 50 mm increments, measured from above.

W (mm)	596	696	
w (mm)	496	596	

D = 680 mm

$h_b$  = 120 mm

$d_f$  = 97 mm

$d_r$  = 97 mm



MOB20097

## Knürr DacoMobile® 1515

- **Material**  
Worktops – sheet steel  
Handle(s) – aluminum extrusion  
Base unit crosspiece – sheet steel
- **Dimensions**  
Height 1,515 mm
- **Color**  
RAL 5003, sapphire blue /  
RAL 7035, light gray
- **Supply schedule**  
1 basic rack  
2 handles  
4 worktops
- **How supplied**  
Partially assembled

W	H	D	w		Order no.	UP
696	1515	685	596		00.106.628.2	1 unit



MOB20098

## Mobile ESD-Measuring and Analysis Station

- **Color combination**  
Worktop, RAL 7035, light gray  
Extrusions and stabilizer,  
RAL 7021 black-gray
- **Castor** – Ø 125 mm
- **Load rating**  
Basic rack: 2,100 N  
Per castor: 750 N  
Surface load per worktop: 800 N
- **Material / Finish**  
Basic rack consists of:  
- Extrusions: extruded aluminum  
- Rockers: die-cast aluminum, powder-coated;
- Sliding handle – aluminum extrusion  
Base unit crosspiece – sheet steel  
Drawer unit, sheet steel  
Table top, sheet steel
- **Supply schedule**  
1 ESD-basic rack  
2 ESD-worktop  
1 ESD-drawer  
1 ESD-handle
- **How supplied**  
Assembled

W	H	D	w	d	Order no.	UP
696	860	685	596	490	00.115.620.9	1 unit

Dimensions in mm: W= Width  
H = Height  
D = Depth  
h = Installation height  
d = Useful depth  
L = Length

HU = Standard height  
unit, 1 HU = 44.45 mm  
19" = 482.6 mm,  
(ideal for 19" components  
in acc. with DIN 41494)  
UP = Unit of packaging  
kg = Weight

Conversion: 1 inch = 25.4 mm  
Replace „x“ with the number of your  
color choice

= assemble to order (shipped within  
10 working days)

Caution: In case of larger orders , delivery  
times may increase.

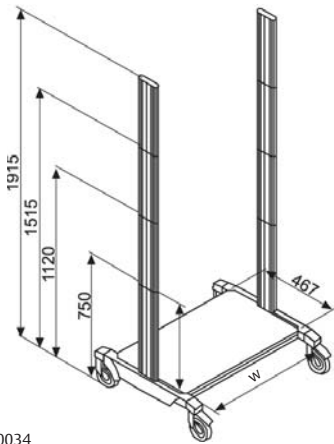

MOB20034



MOB00333



MOB20057

## Knürr DacoMobile® Basic Rack

### Finish

Replace „x“ with the number of your color choice.  
Final digit of order number .1:  
Vertical extrusions, die-cast aluminium runners RAL 7035 Light gray  
Bottom frame cover RAL 7035 Light gray  
Castors, bumper-caps and end-caps black

Final digit of order number .2:  
Vertical extrusions, die-cast aluminium runners RAL 5003 Sapphire blue  
Bottom frame cover RAL 7035 Light gray  
Castors, bumper-caps and end-caps black RAL 5003 Sapphire blue

ESD finish:  
Vertical extrusions, die-cast aluminum runners RAL7021 black grey, ESD  
bottom cover RAL 7035, light gray, ESD

Conductive castors, impact protection caps and end-caps, black

### Supply schedule

1 bottom cover made of sheet steel  
2 die-cast aluminum runners with plastic bumper caps  
4 smooth-running castors – Ø 125 mm, 2 with snib  
2 vertical aluminum extrusions with threaded strips for mounting the modules

Design your own individual equipment carrier as follows:

1. Choose ESD or Standard
2. Select a width
3. Select the height of the basic rack
4. Pick out modules (bear widths in mind)

W	H	w	ESD	Order no.	UP
596	750	496		00.101.505.x	1 unit
696	750	596		00.101.605.x	1 unit
596	750	496	•	00.101.614.9	1 unit
696	750	596	•	00.101.615.9	1 unit
596	1120	496		00.103.505.x	1 unit
696	1120	596	P(.2)	00.103.605.x	1 unit
596	1120	496	•	00.103.614.9	1 unit
696	1120	596	•	00.103.615.9	1 unit
596	1515	496		00.104.505.x	1 unit
696	1515	596	P(.2)	00.104.605.x	1 unit
596	1515	496	•	00.104.614.9	1 unit
696	1515	596	•	00.104.615.9	1 unit
596	1915	496		00.105.505.x	1 unit
696	1915	596	P(.2)	00.105.605.x	1 unit
596	1915	496	•	00.105.614.9	1 unit
696	1915	596	•	00.105.615.9	1 unit

## Knürr DacoMobile® Cable Duct Large

- With convenient hinged cover with two quicklocks
- Separate cable routing via mounting strip
- Cable exit via sealing lips at any height
- Can be mounted left or right

### Material

Sheet steel, powder-coated  
RAL 7035, light gray, antistatic  
ESD: RAL 7021, black-gray, antistatic

### Supply schedule

1 cable duct  
Mounting material

W	H	D	ESD	Order no.	UP
85	1120	190		00.118.014.1	1 unit
85	1515	190		00.118.015.1	1 unit
85	1915	190		00.118.016.1	1 unit
85	1120	190	•	00.118.214.9	1 unit
85	1515	190	•	00.118.215.9	1 unit
85	1915	190	•	00.118.216.9	1 unit



MOB20067

## Knürr DacoMobile® Castor Set

- Load capacity:** 750 N per castor – ø 125 mm
- Color**  
Standard castors: RAL 5003, sapphire blue  
ESD: Black
- Supply schedule**  
4 smooth-running castors  
2 with stopper

w	H	D	ESD	Order no.	UP
				00.128.965.2	1 unit
			•	00.128.975.9	1 unit

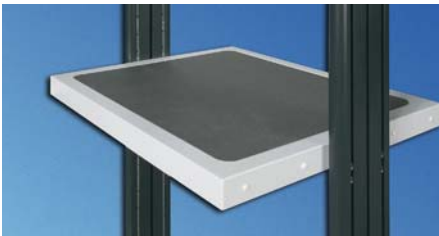

MOB20071

version: sheet steel

## Knürr DacoMobile® Worktop

- Material**  
sheet steel, powder-coated
- Color**  
RAL 7035, light gray  
ESD version:  
RAL 7035, light gray, ESD
- Supply schedule**  
1 worktop  
Mounting material
- Note**  
Please order handle and anti-slide mats separately.

H	D	w	Model	ESD	Order no.	UP
50	490	496	Sheet steel		00.101.530.1	1 unit
50	490	596	Sheet steel		00.101.630.1	1 unit
50	490	496	Sheet steel, ESD	•	00.101.540.1	1 unit
50	490	596	Sheet steel, ESD	•	00.101.640.1	1 unit

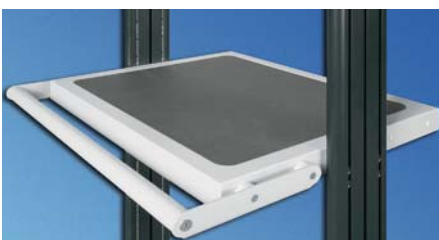

MOB20070

## Knürr DacoMobile® Worktop Handle

- For sheet steel worktops
- Can be mounted from front and/or rear
- Material**  
Sheet steel  
Aluminum extrusion handle
- Color**  
RAL 7035, light gray  
ESD: RAL 7021, dark gray, antistatic
- Supply schedule**  
1 handle  
2 mounting brackets  
Mounting material

w	Model	ESD	Order no.	UP
496	Dacomobile worktop handle		00.101.045.1	1 unit
596	Dacomobile worktop handle		00.101.050.1	1 unit
496	Dacomobile worktop handle ESD	•	00.101.145.1	1 unit
596	Dacomobile worktop handle ESD	•	00.101.150.1	1 unit

Dimensions in mm: W= Width  
H = Height  
D = Depth  
h = Installation height  
d = Useful depth  
L = Length

HU = Standard height unit, 1 HU = 44.45 mm  
19" = 482.6 mm, (ideal for 19" components in acc. with DIN 41494)  
UP = Unit of packaging  
kg = Weight

Conversion: 1 inch = 25.4 mm  
Replace „x“ with the number of your color choice

**P** = assemble to order (shipped within 10 working days)

Caution: In case of larger orders , delivery times may increase.

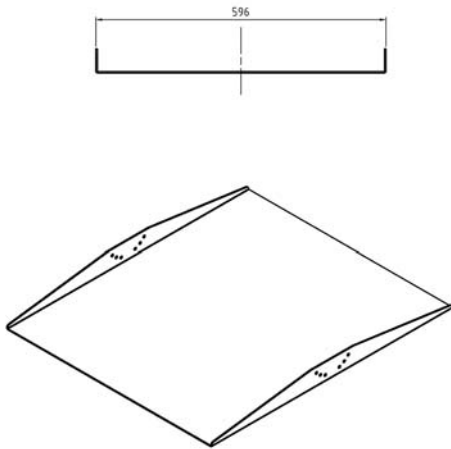

## Tiltable Mounting Plate

- Universal mounting plate. Can be mounted in three different angle positions
- Maximum static surface load: 20kg

**Material**  
Sheet-steel, powder-coated

**Finish**  
RAL 7035 Light-gray

**Supply schedule**  
1 mounting plate  
Mounting material

W	D	w	Order no.	UP
596	600	496	00.101.134.1	1 unit
696	600	596	00.101.135.1	1 unit
596	700	496	00.101.137.1	1 unit
696	700	596	00.101.138.1	1 unit



MOB20063

## Knürr DacoMobile® Cross Extrusion

- For cross-bracing the basic rack with heavy components or with high carts

**Material**  
Sheet steel, powder-coated

Final digit of order number  
.2: RAL 5003 Sapphire blue  
Final digit of order number  
.9: ESD version, RAL 7021 black-gray ESD

**Finish**  
Final digit of order number  
.1: RAL 7035 Light-gray

**Supply schedule**  
1 cross extrusion  
Mounting material

H	w	Model	ESD	Order no.	UP
496		Sheet steel		00.122.510.X	1 unit
596		Sheet steel		00.122.611.X	1 unit
496		Sheet steel, ESD	•	00.122.510.9	1 unit
596		Sheet steel, ESD	•	00.122.611.9	1 unit



MOB20050

## Knürr DacoMobile® Keyboard Extension Open

- ESD or standard version
- Extension board with telescopic slides
- Mouse table can be moved to the left or right

**Material**  
Sheet steel, powder-coated  
Tray handle – plastic

**Color**  
Extension board, mouse table:  
RAL 7035, light-grey, antistatic  
Standard tray handle, RAL 5003,  
sapphire blue  
ESD handle, black

**Supply schedule**  
1 keyboard extension, open,  
with mouse table  
Mounting material

H	D	w	Model	ESD	Order no.	UP
50	490	496	Sheet steel		00.125.525.2	1 unit
50	490	596	Sheet steel		00.125.625.2	1 unit
50	490	496	Sheet steel, ESD	•	00.125.530.1	1 unit
50	490	596	Sheet steel, ESD	•	00.125.630.1	1 unit





MOB20074

## Knürr DacoMobile® Keyboard Extension Closed

- ESD or standard version
- Closed sheet steel carcass
- Main unit cover recessed for optional anti-slide mats
- Extension board with telescopic slides
- Mouse table can be moved to the left or right with or without lock

**Material**  
Sheet steel, powder-coated  
Tray handle – plastic

**Color**  
Main unit, extension board, mouse table:  
RAL 7035, light-grey, antistatic  
Standard tray handle, RAL 5003,  
sapphire blue  
ESD handle, black

**Supply schedule**  
1 keyboard extension, closed,  
with mouse table  
Mounting material

H	D	w	Model	ESD	Order no.	UP
100	490	496	With lock		00.127.516.2	1 unit
100	490	596	With lock		00.127.616.2	1 unit
100	490	496	With lock	•	00.127.526.1	1 unit
100	490	596	With lock	•	00.127.626.1	1 unit



MOB20072



MOB20073

## Knürr DacoMobile® Drawer Module

- ESD or standard version
- With or without lock
- Height – 100 or 150 mm
- Sheet steel main unit
- Main unit cover with depression for optional anti-slide mats

**Material**  
Sheet steel, powder-coated  
Tray handle – plastic

**Color**  
Main unit, drawer  
RAL 7035, light gray, antistatic  
Tray handle: Standard RAL 5003,  
sapphire blue  
ESD handle: Black

**Supply schedule**  
1 drawer module  
Mounting material

H	D	w	Model	ESD	Order no.	UP
100	490	496	With lock		00.117.536.2	1 unit
100	490	596	With lock		00.117.616.2	1 unit
100	490	496	With lock	•	00.117.526.1	1 unit
100	490	596	With lock	•	00.117.626.1	1 unit
150	490	496	With lock		00.117.538.2	1 unit
150	490	596	With lock		00.117.618.2	1 unit
150	490	496	With lock	•	00.117.528.1	1 unit
150	490	596	With lock	•	00.117.628.1	1 unit

Dimensions in mm: W= Width  
H = Height  
D = Depth  
h = Installation height  
d = Useful depth  
L = Length

HU = Standard height  
unit, 1 HU = 44.45 mm  
19" = 482.6 mm,  
(ideal for 19" components  
in acc. with DIN 41494)  
UP = Unit of packaging  
kg = Weight

Conversion: 1 inch = 25.4 mm  
Replace „x“ with the number of your  
color choice

**P** = assemble to order (shipped within  
10 working days)

Caution: In case of larger orders , delivery  
times may increase.



MOB20068

## Knürr DacoMobile® Storage Tray

- Tray for paper, cables or small parts
- Height 80 mm
- With perforation Ø 8 mm

**Material**  
Sheet steel, powder-coated

**Color**  
RAL 7035, light gray, antistatic

**Supply schedule**  
1 storage tray  
Mounting material

H	D	w	Model	ESD	Order no.	UP
80	490	496	ESD	•	00.111.512.1	1 unit
80	490	596	ESD	•	00.111.612.1	1 unit



MOB20067

## Knürr DacoMobile® Mounting Kit, Fixed for 19" DoubleProRack Enclosures

- Installation option for two different enclosure depths in the basic rack
- Maximum static load rating, 800 N
- Only for Knürr DacoMobile® width 600 mm!
- Only for Knürr DoubleProRack Enclosure Width 600; depth 500 mm, 600 mm, 700 mm

**Supply schedule**  
1 pair of mounting brackets

**Note**  
More information on 'DoubleProRack':  
[www.pdb.knuerr.com](http://www.pdb.knuerr.com)

W	H	D	Order no.	UP
		500	00.101.130.1	1 unit
		600	00.101.131.1	1 unit
		700	00.101.132.1	1 unit



MOB20082

## Spacer set for DoubleProRack

- Recommended for DoubleProRack enclosures, mounted in DacoMobile® trolley to stabilize the enclosure

**Material**  
Aluminium extrusion, powder-coated  
RAL 7035 light grey

**Supply schedule**  
2x spacer 20mm length  
2x Cylinder head screw M6x60  
2x Spring nut M6  
2x Star washer 6.4mm

W	H	D	Order no.	UP
			00.101.016.1	1 unit

Dimensions in mm: W= Width  
H = Height  
D = Depth  
h = Installation height  
d = Useful depth  
L = Length

HU = Standard height unit, 1 HU = 44.45 mm  
19" = 482.6 mm, (ideal for 19" components in acc. with DIN 41494)  
UP = Unit of packaging  
kg = Weight

Conversion: 1 inch = 25,4 mm  
Replace „x“ with the number of your color choice

**P** = assemble to order (shipped within 10 working days)

Caution: In case of larger orders, delivery times may increase.



MOB20064

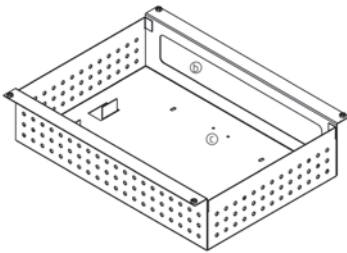

## ESD mounting set for isolating transformer

- Top-Box: Two-piece – bottom panel with cover
- Mounting via the base plate of the Knürr DacoMobile®
- Tray: Mount on underside of base unit
- Secure fixing of the isolating transformers
- With ventilation perforations

**Material**  
Sheet steel, powder-coated

**Color**  
RAL 7035, light gray, antistatic

**Supply schedule**  
1 mounting set  
Mounting material

**Note**  
Only for Knürr Dacomobile:  
W 696 mm, w 596 mm

W	H	D	Model	Order no.	UP
596	140	290	Top-Box	00.101.260.1	1 unit
520	120	350	Tray	00.101.262.1	1 unit



MOB20048

## Knürr DacoMobile® Master Switch Module

- For mounting on the vertical extrusions
- With lit on/off switch, white
- Pre-wired with H05VV-F3G cable, 1.5 mm<sup>2</sup>
- Sheet steel, powder-coated

**Color**  
Standard: RAL 7035, light gray, antistatic

**Supply schedule**  
1 master switch module  
Mounting material

W	H	D	ESD	Order no.	UP
40	76	90		00.118.001.1	1 unit



MOB00298

## Knürr DacoMobile® Rubber Mat

**Material**  
Self-adhesive rubber-mat made of open pore sponge rubber

**Colour**  
Standard: gray, ESD: black

W	D	Model	ESD	Order no.	UP
425	420	Standard, for sheet-steel table top and drawer unit top		00.101.195.0	1 unit
525	420	Standard, for sheet-steel table top and drawer unit top	P	00.101.200.9	1 unit
425	420	Standard, for sheet-steel keyboard extension open		00.105.196.0	1 unit
525	420	Standard, for sheet-steel keyboard extension open		00.101.202.9	1 unit
425	420	ESD, for sheet-steel tabletop and drawer unit top	•	00.101.198.0	1 unit
525	420	ESD, for sheet-steel tabletop and drawer unit top	•	P 00.101.208.9	1 unit
425	420	ESD, for sheet-steel keyboard extension open	•	00.101.199.0	1 unit
525	420	ESD, for sheet-steel keyboard extension open	•	00.101.210.9	1 unit



MOB00402

## Knürr DacoMobile® 19"

**Color**  
RAL 5003, sapphire blue /  
RAL 7035 light-grey

**Supply schedule**  
1 Basic rack  
1 Cross extrusion  
2 19" Extrusions

Installation height 1600.2 mm,  
1733.55 mm  
10 Chassis runners

**How supplied**  
Part assembled

W	H	D	HU/U	h	Order no.	UP
606	1865	685	36	1600,20	<b>01.316.016.2</b>	1 unit
606	2000	685	39	1733,55	<b>01.316.019.2</b>	1 unit



MOB00336

## Knürr DacoMobile® Chassis Runner Set For mounting 19" equipment

**Material**  
Sheet steel, zinc passivated

**Supply schedule**  
2 Chassis runners  
Mounting material

**Dimensions**  
Length: 200 mm  
Thickness: 2 mm  
Angle bracket: 44 x 50 mm

W	H	D	Order no.	UP
50	44	200	<b>01.316.026.7</b>	1 unit

Dimensions in mm: W= Width  
H = Height  
D = Depth  
h = Installation height  
d = Useful depth  
L = Length

HU = Standard height  
unit, 1 HU = 44.45 mm  
19" = 482.6 mm,  
(ideal for 19" components  
in acc. with DIN 41494)  
UP = Unit of packaging  
kg = Weight

Conversion: 1 inch = 25,4 mm

Replace „x“ with the number of your  
color choice



SYN20005

## Knürr SynergyCart® Strong points

### ■ The functional solution

- IT cart for hospitals (ward cart)
  - Equipment cart for health care
  - Test cart in production/workshops
  - Storage consignment, scanner cart
  - Ideal for automotive and industrial projects where small, space-saving carts with cable management are required
- The unmistakable design is harmonized with the Knürr Synergy® product family
  - Fully assembled and turnkey ready for use
  - Tested in accordance to the DIN EN 60601\_1
  - Strong, and yet attractively designed sheet steel basic frame with vertical extruded aluminum supports for the highest possible safety and stability
  - ESD versions of all modules available
  - Modern, smooth-running double wheel castors in conductive version
  - Ergonomics in detail:

All modules can be mounted at any height, absolutely in accordance with the user's individual wishes

- User-friendly cable management with plenty of room for cables, socket strips, isolating transformers, cable exit to the front over the entire height

### ■ Material

- Sheet steel/extruded aluminum tube handle
- Cover with master switch optionally
- Aluminum extrusion vertical supports
- Modules can be mounted stepless on the height via T-slots on the aluminum extrusion
- Welded sheet steel base unit
- Spacious cable exit from the supports in the base tray
- Twin swivel castors, Ø125 mm
- Bumper caps



SYN20024



SYN200090



SYN20002

## Knürr SynergyCart® Computer Cart

The mobile PC workstation, e.g. for stores, office, lab, training

### Material

- Extruded aluminum vertical supports and handle, powder-coated
- Sheet steel basic frame and installation modules, powder-coated
- Plastic bumper caps

### Finish

- .1: RAL 7035 light gray
- .9: Base unit, cover for base unit, bumper caps, handle, extrusion cover, worktops, keyboard extension, holder for tower PC: RAL 7021 dark gray
- Vertical extrusion, handle, vertical cable duct, flat screen holder: RAL 9006 white aluminum

### Load rating

- Permissible total weight: 125 kg
- Load per worktop: 15 kg
- Drawer load: Housing, 10 kg; extension, 2 kg

### Supply schedule

- 1 Knürr SynergyCart® Basic Frame
- 1 vertical cable duct for H 880 mm or H 1,200 mm
- 1 handle
- 1 worktop
- 1 keyboard extension (only with height 1,200 mm)
- 1 flat screen holder
- 1 holder for tower PC
- ESD model with conductive castors and earthing-mounting material

H	ESD	Order no.	UP
880	•	00.705.305.1	1 unit
880	•	00.705.305.9	1 unit
1200	•	00.705.315.1	1 unit
1200	•	00.705.315.9	1 unit

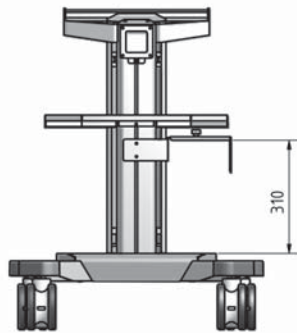

SYN20050

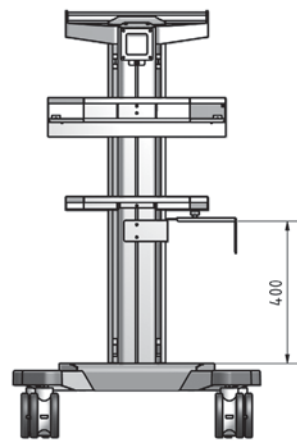
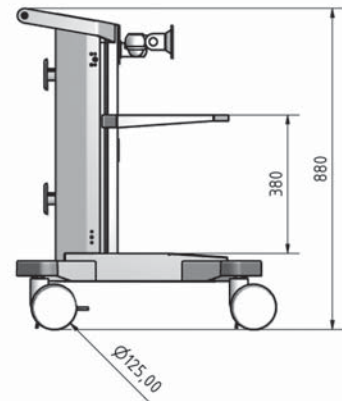

SYN20051

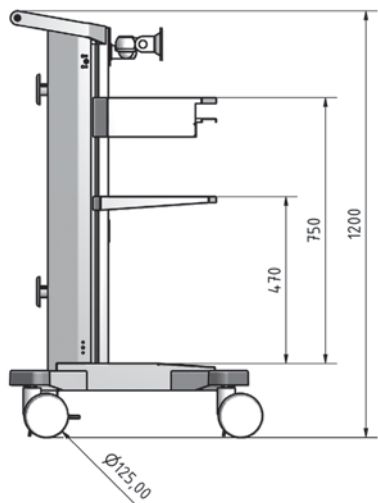

Dimensions in mm: W= Width

H = Height

D = Depth

h = Installation height

d = Useful depth

L = Length

HU = Standard height unit, 1 HU = 44.45 mm

19" = 482.6 mm,

(ideal for 19" components in acc. with DIN 41494)

UP = Unit of packaging

kg = Weight

Conversion: 1 inch = 25,4 mm

Replace „x“ with the number of your color choice



SYN20000

## Knürr SynergyCart® Laptop Cart

### Flexible use in hospitals, offices, test environments, labs

#### Material

- Extruded aluminum vertical supports and handle, powder-coated
- Sheet steel basic frame and installation modules, powder-coated
- Plastic bumper caps

#### Finish

- .1: RAL 7035 light gray
- .9: Base unit, cover for base unit, bumper caps, handle, extrusion cover, worktops, drawer: RAL 7021 dark gray
- Vertical extrusion, handle, vertical cable duct: RAL 9006 white aluminum

#### Load rating

- Permissible total weight: 125 kg
- Load per worktop: 15 kg
- Drawer load: Housing, 10 kg; extension, 2 kg

#### Supply schedule

- 1 basic frame H 880 mm or 1,200 mm
- 1 cable duct for H 880 mm or H 1,200 mm
- 1 handle
- 1 worktop, small
- 1 worktop, large
- 1 drawer
- ESD model with conductive castors and earthing-mounting material

H	ESD	Order no.	UP
880	•	00.705.325.1	1 unit
880	•	00.705.325.9	1 unit
1200	•	00.705.335.1	1 unit
1200	•	00.705.335.9	1 unit

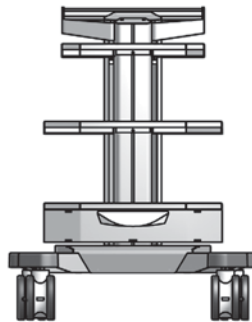

SYN20054

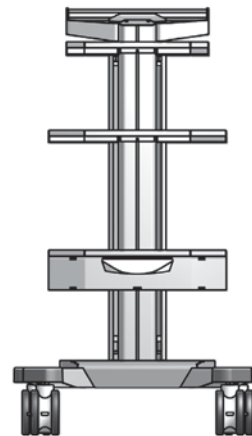
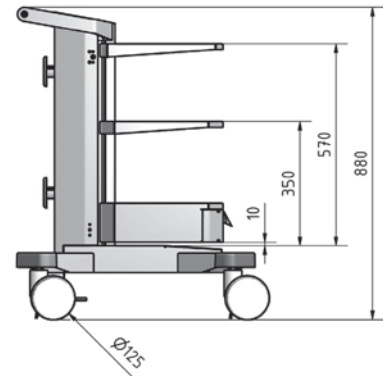

SYN20055

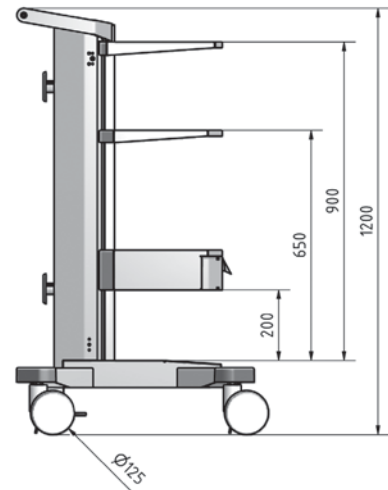

## Knürr SynergyCart® Basic Frame

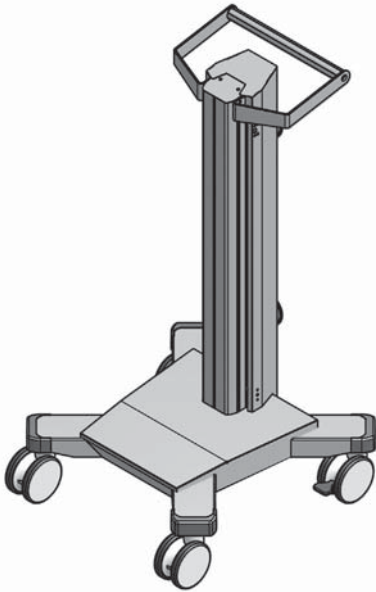

SYN20078

### Base unit

- Robust sheet steel welded construction for highest possible stability
- Foot stabilizer position provides optimum stability
- Double wheel castors, 125 mm in modern design
- Bumper caps for protecting furniture
- Base unit cover is also the surface for mini-tower PCs

### Aluminum vertical extrusion

provides flexible screw-on options with T-slots for Knürr DI-STRIP® socket strips and cable routers. All modules can be mounted at any height with T-slot system on vertical extrusions

### Vertical cable duct

mounted on the rear, plenty of space for cable volumes. Cable exits front and rear over the entire height

### Material

- Extruded aluminum vertical supports and sliding handle, powder-coated
- Sheet steel basic frame and cable duct cover, powder-coated
- Plastic bumper caps

### Finish

- .1: RAL 7035 light gray
- .9: Base unit, cover for base unit, impact protection caps, handle, extrusion cover: RAL 7021 dark gray
- Vertical extrusion, handle, vertical cable duct: RAL 9006 white aluminum

### Load rating

Permissible total weight: 125 kg  
Base unit cover: 10 kg

### Supply schedule

- 1 handle
- 1 extruded aluminum vertical support
- 1 cable duct top cover
- 1 vertical cable duct
- 1 base unit
- Mounting material
- ESD model with conductive castors and earthing material

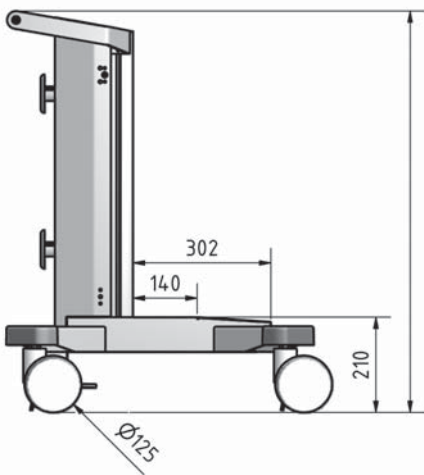

SYN20080

H	ESD	Order no.	UP
880	•	00.705.105.1	1 unit
1200	•	00.705.125.1	1 unit
880	•	00.705.105.9	1 unit
1200	•	00.705.125.9	1 unit

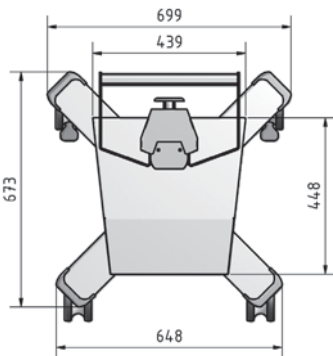

SYN20079

Dimensions in mm: W= Width

H = Height

D = Depth

h = Installation height

d = Useful depth

L = Length

HU = Standard height

unit, 1 HU = 44.45 mm

19" = 482.6 mm,

(ideal for 19" components

in acc. with DIN 41494)

UP = Unit of packaging

kg = Weight

Conversion: 1 inch = 25,4 mm

Replace „x“ with the number of your color choice





SYN20005



SYN20000

## Knürr SynergyCart® Worktop

- Can be ergonomically mounted at any height, stepless
- Torsion-free and stable
- With recessed surface to prevent sliding and for anti-slip mats

**Material**  
Sheet steel, powder-coated

**Finish**  
.1: RAL 7035 light gray  
.9: RAL 7021 dark gray

**Load rating**  
15 kg

**Supply schedule**  
1 worktop  
Mounting material

W	T	ESD	Order no.	UP
400	300	•	00.705.205.1	1 unit
400	300	•	00.705.205.9	1 unit
500	300	•	00.705.225.1	1 unit
500	300	•	00.705.225.9	1 unit



SYN20002

## Knürr SynergyCart® Keyboard Extension

- Can be ergonomically mounted at any height, stepless
- Keyboard extension with mouse table, can be pushed out on the right or left
- Stable extension enclosure with telescopic slides
- Enclosure cover can be used as storage level
- With drawer safety catch against unintentional opening
- Also as ESD version

**Material**  
Main unit and extension: Sheet steel, powder-coated

**Dimensions**  
width, 505 mm; depth, 350 mm;  
height, 110 mm  
drawer width, 490 mm;  
depth, 210 mm

**Load rating**  
Housing, 10 kg; extension, 2 kg

**Supply schedule**  
1 keyboard extension  
Mounting material

W	H	D	ESD	Order no.	UP
505	110	350	•	00.705.255.x	1 unit



SYN20006



## Knürr SynergyCart® Drawer

- Can be ergonomically mounted at any height, stepless
- With drawer safety catch against unintentional opening
- Also as ESD version

**Material**  
Main unit and drawer: Sheet steel, powder-coated  
Handle: Plastic, black

**Finish**  
.1: RAL 7035 light gray  
.9: RAL 7021 dark gray

**Dimensions**  
width, 505 mm; depth, 350 mm; height, 110 mm  
drawer width, 425 mm; depth, 265 mm; height, 90mm

**Load rating**  
Housing, 10 kg; extension, 2 kg

**Supply schedule**  
1 drawer module  
Mounting material

W	H	D	ESD	Order no.	UP
500	300	110	•	00.705.275.x	1 unit



SYN20024

## Knürr SynergyCart® Main Switch Module

- Top extrusion cover with central switch
- Lit switch, IP 54
- Cabled with 3.5 m mains cable with Schuko plug and outgoing 2 m cable with Euro plug, 1.5 mm<sup>2</sup> cross-section each for device cabling or as connector for Knürr DI-STRIP® socket strip
- Hidden cable routing in the vertical extrusion

**Material**  
Extrusion cover: Sheet steel, powder-coated

**Finish**  
Extrusion cover:  
.1: RAL 7035 light gray  
.9: RAL 7021 dark gray

**Supply schedule**  
1 central switch module  
Mounting material

Order no.	UP
00.705.280.x	1 unit



SYN20024

## Knürr SynergyCart® Holder for PC Tower Enclosure

- Adjustable holder clamp for mini-tower PC
- The basic frame's top cover serves as a platform

**Material**  
Sheet steel, powder-coated

**Finish**  
.1: RAL 7035 light gray  
.9: RAL 7021 dark gray

**Dimensions**  
Adjustable width, 160 – 220 mm  
Height-variable with T-slot mounting

**Supply schedule**  
1 set of holders for PC tower enclosures  
Mounting material

W	Order no.	UP
160-220	00.705.236.x	1 unit



SYN20015

## Knürr SynergyCart® Transformer Tray

- For mounting on the underside of the base unit
- The low mounting position increases tilt stability with optimum weight distribution
- With ventilation openings on the sides and in the base for safe heat dissipation

**Material**  
Sheet steel, powder-coated

**Finish**  
.1: RAL 7035 light gray  
.9: RAL 9006 white aluminum

**Dimensions**  
Useful depth, 370 mm  
Height, 60 mm, usable height 110mm  
Width, 294 mm

**Load rating**  
20 kg

**Supply schedule**  
1 transformer tray  
Mounting material

**Note**  
Designed for isolating-transformer, B/N 00.100.842.9 (see page 35)

W	H	D	d	Order no.	UP
294	60	408	370	00.705.230.x	1 unit

# Knürr SynergyCart®

Comfortable adjustable by gas lift column

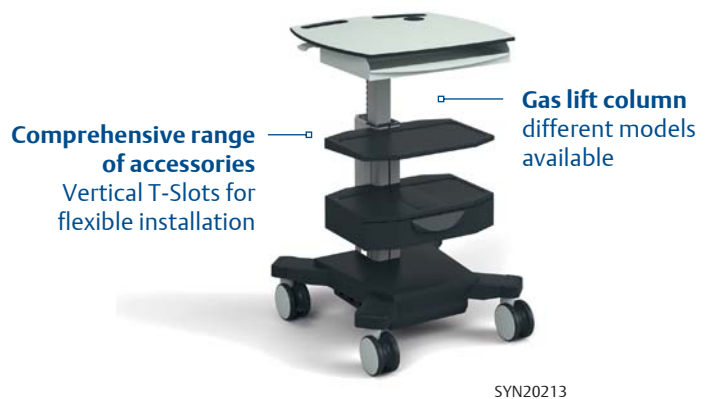
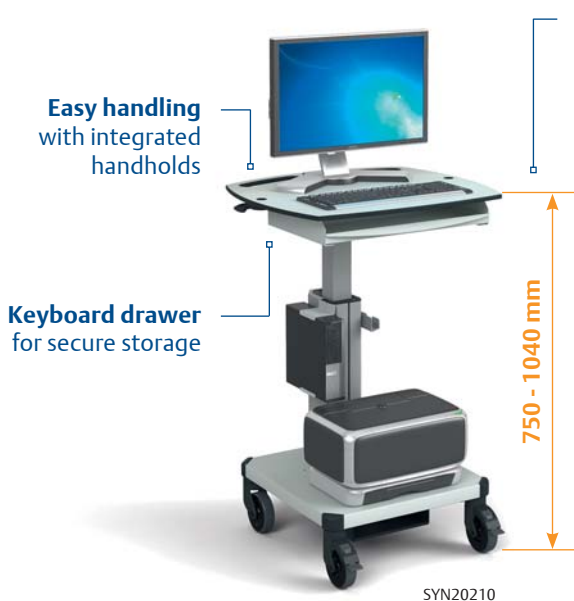

## Individual Project Solutions – Contact Us!

Many application scenarios demand a project specific solution. When planning, manufacturing, and assembling your individual requirements, Knürr takes multiple factors into account, including your personal requirements as well as legal guidelines. Industrial designers and Technicians closely cooperate at our product design department to bring form and function in line. The resulting designs are regularly tested by means of 3D-CAD models and you are welcome to incorporate your ideas any time. Any required prototypes are manufactured by experts who translate your wishes and ideas into a real product.



## Knürr Cabinet Cart - Rollo

### Strong points

#### ■ Aesthetics

- Clear lines and curved shapes for a compact and modern look
- Rear and Side panels with square hole design perforation provide additional functions, e.g. for ventilation and hook-in accessories
- Space-saving cabling area, aesthetically integrated in rear

#### ■ Functionality

- Suitable for the most varied areas of application: PC or printer station, IT-cart, logistics or laboratory as well as workshops or assembly and manufacturing applications
- Space-saving footprint (710 x 870 mm)
- Already implemented cable management

#### ■ Features

- Maximum static load rating:
  - Overall load rating of each cabinet cart: 1500 N
  - per Castor: 750N
  - Surface load of worktop: 400 N
  - Distributed load of shelf: 400 N

#### ■ Material

- All Side panels, shelves, or similar are made from powder coated sheet steel
- Worktop out of high quality multi layer chipboard with HP laminate surfaces, which enable high load ratings and ensure long durability.
- Bumpers (main frame cover) out of special plastics

#### ■ Available accessories

- Toolholder
- Flat screen holder
- Handle
- Socket strip (e.g. 6 way+switch)

#### ■ Variability

- Numerous individual configurations possible
- All modules can be combined and mounted in the easiest possible way
- Simple and quick adjustment without special tools



## Knürr Cabinet Cart - Rollo

- Knürr Cabinet Cart toolholder can be mounted easily at the rear panel, via square hole design perforation
- Lockable roller blind door
- Vibration-free and noiseless transport with special rubber smooth-running castors Ø 125mm (4 casters, 2 lockable)
- Bumpers, made out of special plastics
- Cabinet Cart handles (bow shaped) can be mounted on left- and rightside

**Color**  
Color combination .9  
(as shown in the picture)

- Supply schedule**
- 1 basic frame incl. 4 casters
  - 2 vertical extrusions (rear)
  - 2 side panels
  - 1 rear panel
  - 1 top cover
  - 1 shelf

**How supplied**  
fully assembled

**Castors**  
RAL9011, graphite black

W	H	D	d	Order no.	UP
				00.713.200.9	1 unit

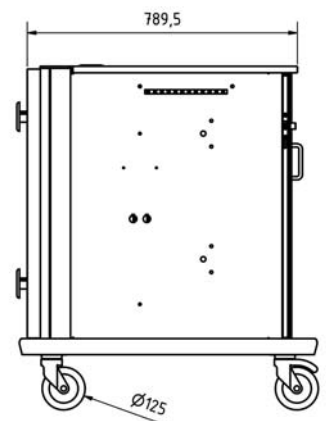
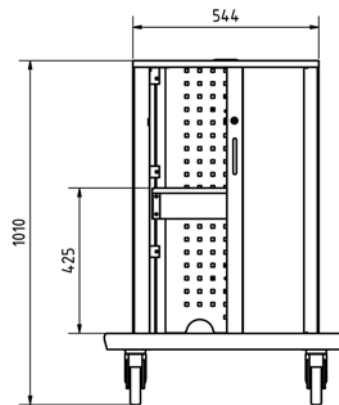
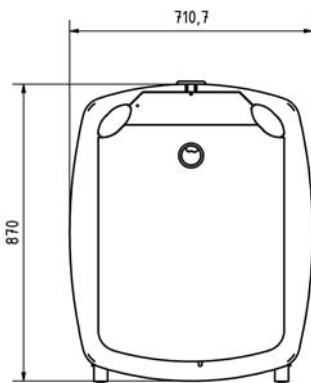

## Flat screen holder

- Monitor arms for mounting flat screens with the 75 and 100 mm VESA mounting

**Supply schedule**

- 1 flat screen support
- 1 Monitor pole 400 mm
- Mounting material

**How supplied**  
Flat-packed kit

**Finish / Material**

- Swivel arm: die-cast aluminium
- Adapter plates: sheet steel
- Metal parts: powder-coated, RAL 9006, White aluminium, smooth

H	Order no.	UP
400	01.316.229.9	1 unit



Dimensions in mm: W= Width  
H = Height  
D = Depth  
h = Installation height  
d = Useful depth  
L = Length

HU = Standard height unit, 1 HU = 44,45 mm  
19" = 482,6 mm, (ideal for 19" components in acc. with DIN 41494)  
UP = Unit of packaging  
kg = Weight

Conversion: 1 inch = 25,4 mm  
Replace „x“ with the number of your color choice

**P** = assemble to order (shipped within 10 working days)

Caution: In case of larger orders, delivery times may increase.

## Knürr Cabinet Cart Strong points



■ RAL3003 Ruby  
■ RAL7035 Light grey

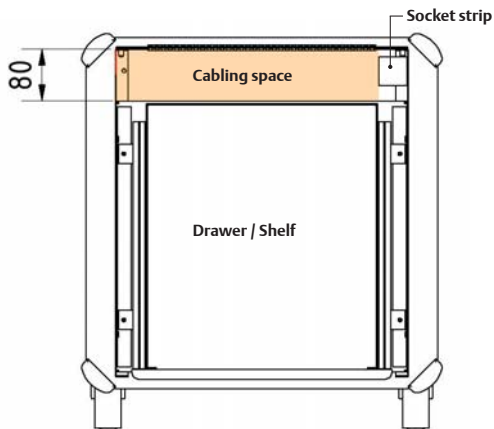

Top view (top cover removed)

### Aesthetics

- Clear lines and straight shapes for a compact and modern look
- Huge variety of different color options
- Rear and Side panels with square hole design perforation provide additional functions, e.g. for ventilation and hook-in accessories
- Space-saving cabling area, aesthetically integrated in rear

### Functionality

- Suitable for the most varied areas of application:  
PC or printer station, IT-cart, logistics or laboratory as well as workshops or assembly and manufacturing applications
- Space-saving footprint (550 x 550 mm)
- Already implemented cable management

### Features

- Modules can be installed at increments of 50mm
- Maximum static load rating:
  - Overall load rating of each cabinet cart: 1500 N
  - Per castor: 750 N
  - Surface load of worktop: 400 N
  - Distributed load of shelf: 400 N
  - Distributed load drawer extension up to 100 N

### Material

- All drawers, shelves, or similar are made from powder coated sheet steel

### Available accessories

- Hooks
- Cable management (hook on block)
- Shelves
- Drawer
- Front door
- Flat screen holder
- Handle
- Socket strip (e.g. 6 way+switch)

### Variability

- Numerous individual configurations possible
- All modules can be combined and mounted in the easiest possible way
- Individual configuration with adjustment of several components (e.g. shelves) at intervals
- Simple and quick adjustment without special tools

### Convenience

- Easy to clean with coated surfaces
- All surfaces are corrosion-free, impact and scratch-proof and acid and disinfection agent resistant
- Vibration-free and noiseless transport with special rubber smooth-running castors  
Ø 125 mm (4 casters, 2 lockable)



■ RAL3003 Ruby  
■ RAL7035 Light grey

■ RAL7035 Light grey  
■ RAL7016 Anthracite

■ RAL7035 Light grey  
■ RAL5003 Sapphire blue

■ RAL7016 Anthracite  
■ RAL7035 Light grey

■ RAL5003 Sapphire blue  
■ RAL7035 Light grey



## Knürr Cabinet Cart Basic

### A Cabinet Cart Basic consists of:

- 1 base frame incl. 4 castors
- 2 side panels
- 1 rear panel
- 1 top cover
- 1 shelf

**Material**  
Sheet steel, powder coated

**How supplied**  
Fully assembled

### Color combination Finish: Replace X with the number of your color choice:

- |   |                      |
|---|----------------------|
| Final digit number .1:<br>Body and side panels light grey | RAL7035 Light grey   |
| Final digit number .2:<br>Body saphire blue               | RAL5003 Saphire blue |
| Side panels light grey                                    | RAL7035 Light grey   |
| Final digit number .3:<br>Body light grey                 | RAL7035 Light grey   |
| Side panels saphire blue                                  | RAL5003 Saphire blue |
| Final digit number .5:<br>Body light grey                 | RAL7035 Light grey   |
| Side panels ruby  | RAL3003 Ruby         |
| Final digit number .8:<br>Body light grey                 | RAL7035 Light grey   |
| Side panels anthracite                                    | RAL7016 Anthracite   |
| Final digit number .9:<br>Body anthracite                 | RAL7016 Anthracite   |
| Side panels light grey                                    | RAL7035 Light grey   |

**Castors**  
RAL 9011, graphite black

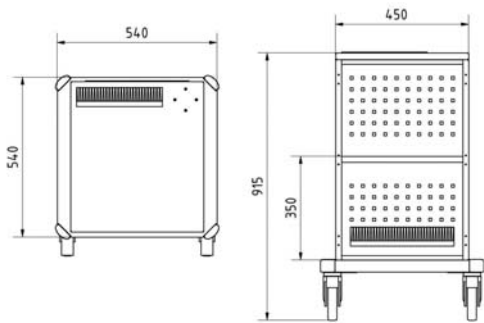

	Order no.	UP
(.1 and .9)	00.713.100.x	1 unit



## Knürr Cabinet Cart Workshop

### A Cabinet Cart Workshop consists of:

- 1 base frame incl. 4 castors
- 2 side panels
- 1 rear panel
- 1 top cover
- 2 shelves
- 1 front door (lockable)
- 2 hook on blocks
- 1 handle
- 1 socket strip (6-way incl. switch)

**Material**  
Sheet steel, powder coated

**How supplied**  
Fully assembled

### Color combination Finish: Replace X with the number of your color choice:

- |   |                      |
|---|----------------------|
| Final digit number .1:<br>Body and side panels light grey | RAL7035 Light grey   |
| Final digit number .2:<br>Body saphire blue               | RAL5003 Saphire blue |
| Side panels light grey                                    | RAL7035 Light grey   |
| Final digit number .3:<br>Body light grey                 | RAL7035 Light grey   |
| Side panels saphire blue                                  | RAL5003 Saphire blue |
| Final digit number .5:<br>Body light grey                 | RAL7035 Light grey   |
| Side panels ruby  | RAL3003 Ruby         |
| Final digit number .8:<br>Body light grey                 | RAL7035 Light grey   |
| Side panels anthracite                                    | RAL7016 Anthracite   |
| Final digit number .9:<br>Body anthracite                 | RAL7016 Anthracite   |
| Side panels light grey                                    | RAL7035 Light grey   |

**Castors**  
RAL 9011, graphite black

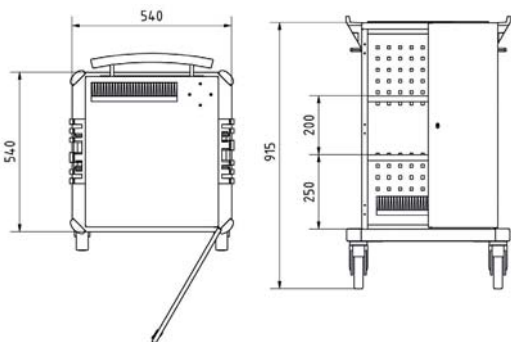

	Order no.	UP
(.1 and .9)	00.713.101.x	1 unit



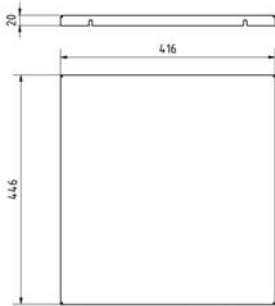

## Shelf

- Material**  
Sheet steel, powder coated
- Supply schedule**  
1 Shelf incl. mounting material

- Color**  
**Finish: Replace X with the number of your color choice:**  
Final digit number .1: Shelf light grey  
Final digit number .2: Shelf sapphire blue  
Final digit number .5: Shelf ruby  
Final digit number .9: Shelf anthracite

- Load rating**  
Surface load: 400 N

W	H	D	Order no.	UP
446	20	416	<b>P</b> (.1 and .9) <b>00.713.102.x</b>	1 unit

## Front Door Lockable



- Material**  
Sheet steel, powder coated
- Supply schedule**  
1 Lockable front door incl. hinges and mounting material (mountable on left or right side)

- Color**  
**Finish: Replace X with the number of your color choice:**  
Final digit number .1: Front Door light grey  
Final digit number .2: Front Door sapphire blue  
Final digit number .5: Front Door ruby  
Final digit number .9: Front Door anthracite

Order no.	UP
<b>P</b> (.1 and .9) <b>00.713.105.x</b>	1 unit

Dimensions in mm: W= Width  
H = Height  
D = Depth  
h = Installation height  
d = Useful depth  
w = Usefuel width  
L = Length

HU = Standard height  
unit, 1 HU = 44.45 mm  
19" = 482.6 mm,  
(ideal for 19" components  
in acc. with DIN 41494)  
UP = Unit of packaging  
kg = Weight

Conversion: 1 inch = 25.4 mm  
Replace „x“ with the number of your  
color choice

**P** = assemble to order (shipped within  
10 working days)

Caution: In case of larger orders , delivery  
times may increase.



## Cabinet Cart Drawer 50 mm Compact Keyboard Extension

- Height 50mm
- Position below top cover
- As utility box or compact keyboard drawer

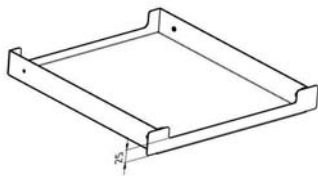
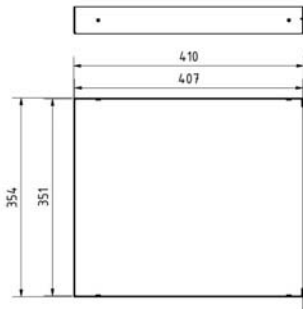

**Material**  
Sheet steel, powder coated

**Supply schedule**  
1 Drawer incl. mounting material

**Color**  
**Finish: Replace X with the number of your color choice:**

- Final digit number .1:
- Drawer light grey
- Final digit number .2:
- Drawer sapphire blue
- Final digit number .5:
- Drawer ruby
- Final digit number .9:
- Drawer anthracite

**Load rating**  
Drawer extension: 100 N

w	h	d	Order no.	UP
351	50	407	(.1 and .9) <b>00.713.103.x</b>	1 unit



## Cabinet Cart Drawer 150 mm

- Height 150mm
- Storage drawer
- Position at various heights

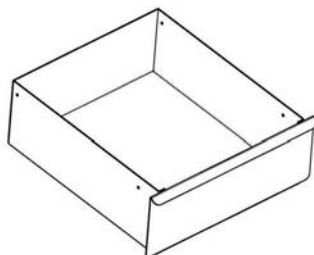
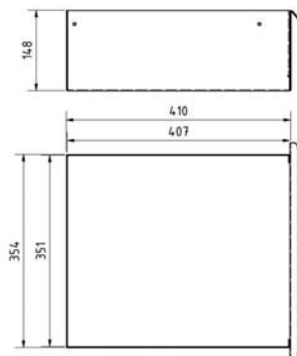

**Material**  
Sheet steel, powder coated

**Supply schedule**  
1 Drawer incl. mounting material

**Please note**  
You may order a shelf to cover the drawer module

**Color**  
**Finish: Replace X with the number of your color choice:**

- Final digit number .1:
- Drawer light grey
- Final digit number .2:
- Drawer sapphire blue
- Final digit number .5:
- Drawer ruby
- Final digit number .9:
- Drawer anthracite

**Load rating**  
Drawer extension: 100 N

w	h	d	Order no.	UP
350	150	405	(.1 and .9) <b>00.713.104.x</b>	1 unit

Dimensions in mm: W= Width  
H = Height  
D = Depth  
h = Installation height  
d = Useful depth  
L = Length

HU = Standard height unit, 1 HU = 44.45 mm  
19" = 482.6 mm, (ideal for 19" components in acc. with DIN 41494)  
UP = Unit of packaging  
kg = Weight

Conversion: 1 inch = 25,4 mm  
Replace „x“ with the number of your color choice

= assemble to order (shipped within 10 working days)

Caution: In case of larger orders, delivery times may increase.



## Hook-On Block For holding test pins

**Material**  
Plastic

**Color**  
RAL 9011, graphite black

**Supply schedule**  
1 hook-on block  
Mounting material

W	H	D	Order no.	UP
220	120	55	<b>00.701.090.9</b>	1 unit



## Toolholder

- Toolholder / Accessoires
- To hook into square hole perforation of side and rear panels
- Impact and scratch-proof plastic coatings
- Base plate thickness 1,5 mm (embossed)
- Including an original locking screw

- Locking screw:
  - The polyamid locking screw prevents side and rear panels from scratches



Description	Order no.	UP
Toolholder - Double Hook 50 mm	<b>00.713.106.0</b>	1 unit
Machine holder - round shaped 60 mm	<b>00.713.106.1</b>	1 unit
Cableholder 150 mm	<b>00.713.106.2</b>	1 unit
Locking screw - 100 pcs	<b>00.713.106.3</b>	1 unit





## Flat screen holder

- Monitor arms for mounting flat screens with the 75 and 100 mm VESA mounting

- Supply schedule**
  - 1 flat screen support
  - 1 Monitor pole 400 mm
  - Mounting material

**How supplied**  
Flat-packed kit

- Finish / Material**
  - Swivel arm: die-cast aluminium
  - Adapter plates: sheet steel
  - Metal parts: powder-coated, RAL 9006, White aluminum, smooth

H	Order no.	UP
400	01.316.229.9	1 unit



## Handle

Handle (bow shaped)

- Material**  
Aluminium, welded

**Color**  
RAL 9011, graphite black

- Supply schedule**  
1 Handle  
Mounting material

W	H	D	Order no.	UP
420	25	75	00.713.108.0	1 unit

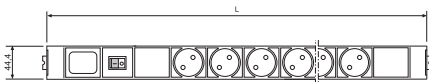

DOS20045

## Socket Strip 6-way incl. Switch

Socket Strip (Schuko) 6-way incl. switch and mounting material

L	Order no.	UP
483	00.713.110.0	1 unit

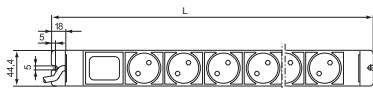

DOS20020

without switch

## Socket Strip 4-way

Socket Strip (Schuko) 4-way and mounting material

L	Order no.	UP
333	00.713.110.5	1 unit

Dimensions in mm: W= Width  
H = Height  
D = Depth  
h = Installation height  
d = Useful depth  
L = Length

HU = Standard height unit, 1 HU = 44.45 mm  
19" = 482.6 mm, (ideal for 19" components in acc. with DIN 41494)  
UP = Unit of packaging  
kg = Weight

Conversion: 1 inch = 25,4 mm  
Replace „x“ with the number of your color choice

**P** = assemble to order (shipped within 10 working days)

Caution: In case of larger orders, delivery times may increase.

## Knürr MetraMobil® Strong points



MET00003



MET 20000



MET00034



MET00037

### ■ Variability

- A completely individual cart can be configured from a basic frame in 2 heights, 3 colors and 5 module components.
- Ideal height adjustment with variable height setting of the shelves

### ■ Stability

- High load rating:
  - up to 600 N per worktop
  - up to 2200 N for full trolley
- Distributed load drawer extension up to 100 N
- High stability with advanced sheet steel construction

### ■ Functionality

- Suitable for the most varied areas of application: PC or printer station, IT-cart, logistics or laboratory

### ■ Cable management

- Safe cable routing with two cable ducts integrated in the extrusion
- Clear and orderly cable management with integration of accessory parts, e.g. a socket strip, which can be mounted on the extrusion.

### ■ Well-thought out solutions

- Vision and contact protection provided by the easy "on-off" rear panel, no tools needed
- Orderly arrangement of small material with drawer module with removeable small parts tray
- Smooth running 3/4 pull-out "Quattro" guide

### ■ ESD versions

- Safety and protection in demanding ESD environments provided by ESD castors and ESD powder coating.



MET00018 Metramobil Basic height 1120 mm



MET00014 Metramobil Basic height 900 mm



MET20008 Metramobil light

## Knürr MetraMobil® Basic Configurations

Replace „x“ with the number of your color choice.

- **Final digit of order number .1:**  
Worktops, RAL 7035, light-grey Extrusions, RAL 9006, white aluminium  
Handle, RAL 9011, graphite black
- **Final digit of order number .2:**  
Worktops, NCS 3060 R80B, blue Extrusions, RAL 9006, white aluminium  
Handle, RAL 9011, graphite black
- **Final digit of order number .9:**  
Worktops, RAL 7016, anthracite grey Extrusions, RAL 9006, white aluminium  
Handle, RAL 9011, graphite black

- **ESD versions:**  
**Note: ESD only in color variant .1 (light gray)**  
**Final digit of order number .1:**  
Worktops, RAL 7035, antistatic light gray  
Extrusions, RAL 9006, white aluminum  
Handle: RAL 7021, dark gray, antistatic

- Design your individual trolley as follows:  
1. Select height of the basic trolley  
2. Select ESD or standard model  
3. Pick out additional modules

- The basic model can be easily expanded with system components (bear ESD in mind!)

- Worktops: set at any height

- **Dimensions**  
Height, 900 mm or 1120 mm  
Full width, 550 mm  
Useful width, 500 mm  
Depth, 580 mm  
Useful depth, 440 mm  
Castor Ø 125 mm

- **Load rating**  
Basic rack: 2200 N  
Per castor: 750 N  
Surface load per worktop: 600 N

- **Material/Finish**  
Basic rack consists of:  
- Extrusions: extruded aluminium, powder-coated  
- Worktops: sheet steel, powder-coat textured  
Handle: aluminium tube, powder-coat textured

- **Supply schedule, Basic Configuration**  
**a. Height 900 mm**  
1 Basic rack  
1 Worktop with handle  
1 Worktop  
**b. Height 1120 mm**  
1 Basic rack  
1 Worktop with handle  
2 Worktops

- **Supply schedule Metramobil Light**  
1 Basic rack  
1 Worktop with handle

- **How supplied**  
Modules for self installation

W	H	D	w	d	ESD	Model	Order no.	UP
550	900	580	500	440			<b>P</b> (.1) 00.709.000.x	1 unit
550	900	580	500	440	•		00.709.100.1	1 unit
550	900	580	500	440		Metramobil light	<b>P</b> (.1) 00.709.200.x	1 unit
550	1120	580	500	440			<b>P</b> (.1) 00.711.000.x	1 unit
550	1120	580	500	440	•		00.711.100.1	1 unit
550	1120	580	500	440		Metramobil light	<b>P</b> (.1) 00.711.200.x	1 unit

Dimensions in mm: W= Width  
H = Height  
D = Depth  
h = Installation height  
d = Useful depth  
L = Length

HU = Standard height unit, 1 HU = 44.45 mm  
19" = 482.6 mm, (ideal for 19" components in acc. with DIN 41494)  
UP = Unit of packaging  
kg = Weight

Conversion: 1 inch = 25,4 mm  
Replace „x“ with the number of your color choice

**P** = assemble to order (shipped within 10 working days)

Caution: In case of larger orders, delivery times may increase.



MET00058

## Knürr MetraMobil® 900

Replace „x“ with the number of your color choice.

- **Final digit of order number .1:**  
Worktops, RAL 7035, light-grey  
Extrusions, RAL 9006, white aluminium  
Handle, RAL 9011, graphite black
- **Final digit of order number .2:**  
Worktops, NCS 3060 R80B, blue  
Extrusions, RAL 9006, white aluminium  
Handle, RAL 9011, graphite black
- **Final digit of order number .9:**  
Worktops, RAL 7016, anthracite grey  
Extrusions, RAL 9006, white aluminium  
Handle, RAL 9011, graphite black

- Worktops: set at any height

- Castor: Ø 125 mm

- **Load rating**  
Basic rack: 2200 N  
Per castor: 750 N  
Surface load per worktop: 600 N

- **Material/Finish**  
Basic rack consists of:  
- Extrusions: extruded aluminium, powder-coated  
- Worktops: sheet steel, powder-coat textured  
Handle: aluminium tube, powder-coat textured

- **Supply schedule**  
1 Basic rack  
1 Worktop with handle  
1 Worktop  
1 Keyboard extension with mouse table

- **How supplied**  
Modules for self installation

W	H	D	w	d		Order no.	UP
550	900	580	500	440	(.1)	00.709.002.x	1 unit



MET00060

## Knürr MetraMobil® 1120

Replace „x“ with the number of your color choice.

- **Final digit of order number .1:**  
Worktops, RAL 7035, light-grey  
Extrusions, RAL 9006, white aluminium  
Handle, RAL 9011, graphite black
- **Final digit of order number .2:**  
Worktops, NCS 3060 R80B, blue  
Extrusions, RAL 9006, white aluminium  
Handle, RAL 9011, graphite black
- **Final digit of order number .9:**  
Worktops, RAL 7016, anthracite grey  
Extrusions, RAL 9006, white aluminium  
Handle, RAL 9011, graphite black

- Worktops: set at any height

- Castor: Ø 125 mm

- **Load rating**  
Basic rack: 2200 N  
Per castor: 750 N  
Surface load per worktop: 600 N

- **Material/Finish**  
Basic rack consists of:  
- Extrusions: extruded aluminium, powder-coated  
- Worktops: sheet steel, powder-coat textured  
Handle: aluminium tube, powder-coat textured

- **Supply schedule**  
1 Basic rack  
1 Worktop with handle  
2 Worktops  
1 Keyboard extension with mouse table

- **How supplied**  
Modules for self installation

W	H	D	w	d		Order no.	UP
550	1120	580	500	440	(.1)	00.711.002.x	1 unit



MET00017

## Knürr MetraMobil® 1120 with drawer module

Replace „x“ with the number of your color choice.

- **Final digit of order number .1:**  
Worktops, RAL 7035, light-grey  
Extrusions, RAL 9006, white aluminium  
Handle, RAL 9011, graphite black
- **Final digit of order number .2:**  
Worktops, NCS 3060 R80B, blue  
Extrusions, RAL 9006, white aluminium  
Handle, RAL 9011, graphite black
- **Final digit of order number .9:**  
Worktops, RAL 7016, anthracite grey  
Extrusions, RAL 9006, white aluminium  
Handle, RAL 9011, graphite black

- Worktops: set at any height

- Castor: Ø 125 mm

- **Load rating**  
Basic rack: 2200 N  
Per castor: 750 N  
Surface load per worktop: 600 N

- **Material/Finish**  
Basic rack consists of:  
- Extrusions: extruded aluminium, powder-coated  
- Worktops: sheet steel, powder-coat textured  
Handle: aluminium tube, powder-coat textured

- **Supply schedule**  
1 Basic rack  
1 Worktop with handle  
2 Worktops  
1 Drawer module

- **How supplied**  
Modules for self installation

W	H	D	w	d		Order no.	UP
550	1120	580	500	440	(.1)	00.711.004.x	1 unit

Dimensions in mm: W= Width  
H = Height  
D = Depth  
h = Installation height  
d = Useful depth  
L = Length

HU = Standard height unit, 1 HU = 44.45 mm  
19" = 482.6 mm, (ideal for 19" components in acc. with DIN 41494)  
UP = Unit of packaging  
kg = Weight

Conversion: 1 inch = 25,4 mm  
Replace „x“ with the number of your color choice

= assemble to order (shipped within 10 working days)

Caution: In case of larger orders, delivery times may increase.





MET00014

## Knürr MetraMobil® Worktop

Replace „x“ with the number of your color choice.

### Standard versions:

**Final digit of order number .1:**

RAL 7035 light-grey

**Final digit of order number .2:**

NCS 3060 R80B, blue

**Final digit of order number .9:**

RAL 7016 anthracite grey

### ESD version:

**Note: ESD only in color variant**

**.1 (light-grey)**

**Final digit of order number .1:**

RAL 7035 anti-static, light-grey

■ For storage and work purposes

■ Variable setting between the vertical extrusions

### ESD model in accordance with EN 100015

#### Supply schedule

1 Worktop

Mounting material

#### How supplied

Flat-packed kit

W	H	D	ESD	Model		Order no.	UP
500	25	440			(.1)	00.701.020.x	1 unit
500	25	440	•			00.701.120.1	1 unit
500	25	440		with handle	(.1)	00.701.021.x	1 unit
500	25	440	•	with handle		00.701.121.1	1 unit

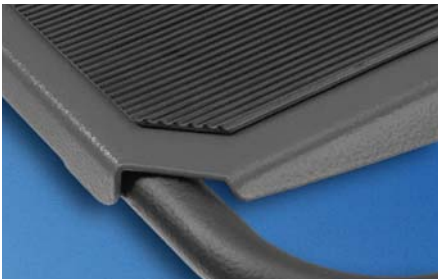

MET00040

## Knürr MetraMobil® Anti-Slide Mat Set

### Note:

**Anti-slide mats are not possible at the same time with keyboard extension!**

■ Consists of 4 anti-slide mats

■ For slide-proof storage of parts to be transported

■ As scratch protection for the worktop

#### Material

Industrial rubber, self-adhesive

#### Color

Black

#### Supply schedule

4 Anti-slide mats

#### How supplied

Flat-packed kit

### ESD model

■ Consisting of four anti-slide mats, ESD, self-adhesive

#### Tests

ESD test in accordance with EN 100015

#### Material

Industrial rubber, antistatic

#### Color

Black

W	H	D	ESD		Order no.	UP
475		430			00.701.070.9	1 unit
475		430	•		00.701.170.9	1 unit



MET00035

## Knürr MetraMobil® Keyboard Extension

Replace „x“ with the number of your color choice.

### Standard versions:

**Final digit of order number .1:**

RAL 7035 light-grey

**Final digit of order number .2:**

NCS 3060 R80B, blue

**Final digit of order number .9:**

RAL 7016 anthracite grey

### ESD version:

**Note: ESD only in color variant .1 (light-grey)**

**Final digit of order number .1:**

RAL 7035 anti-static, light-grey

- For mounting on Knürr MetraMobil® worktop and worktop with handle

- With side mouse table, left/right

- Extension 200 mm

**ESD model in accordance with EN 100015**

### Supply schedule

1 Keyboard extension  
Mounting material

### How supplied

Flat-packed kit

### Note

With worktop with keyboard extension, an anti-slide mat is not possible!

W	H	D	ESD		Order no.	UP
505	45	200		(.1)	<b>00.701.060.x</b>	1 unit
505	45	200	•		<b>00.701.160.1</b>	1 unit



MET00017

## Knürr MetraMobil® Drawer Module

Replace „x“ with the number of your color choice.

### Standard versions:

**Final digit of order number .1:**

RAL 7035 light-grey

**Final digit of order number .2:**

NCS 3060 R80B, blue

**Final digit of order number .9:**

RAL 7016 anthracite grey

### ESD version:

**Note: ESD only in color variant .1 (light-grey)**

**Final digit of order number .1:**

RAL 7035 anti-static, light-grey

- For holding small material

- Including divider set

### Material/Finish

Sheet steel, powder-coat textured

**ESD model in accordance with EN 100015**

### Supply schedule

1 Drawer module  
Mounting material

### How supplied

Flat-packed kit

W	H	D	ESD		Order no.	UP
500	165	440		(.1)	<b>00.701.001.x</b>	1 unit
500	165	440	•		<b>00.701.101.1</b>	1 unit

Dimensions in mm: W= Width  
H = Height  
D = Depth  
h = Installation height  
d = Useful depth  
L = Length

HU = Standard height unit, 1 HU = 44.45 mm  
19" = 482.6 mm, (ideal for 19" components in acc. with DIN 41494)  
UP = Unit of packaging  
kg = Weight

Conversion: 1 inch = 25,4 mm

Replace „x“ with the number of your color choice

= assemble to order (shipped within 10 working days)

Caution: In case of larger orders, delivery times may increase.



MET00033

## Knürr MetraMobil® Rear Panel

Replace „x“ with the number of your color choice.

### Standard versions:

**Final digit of order number .1:**

RAL 7035 light-grey

**Final digit of order number .2:**

NCS 3060 R80B, blue

**Final digit of order number .9:**

RAL 7016 anthracite grey

### ESD version:

**Note: ESD only in color variant**

**.1 (light-grey)**

**Final digit of order number .1:**

RAL 7035 anti-static, light-grey

■ With cable entry

■ ESD model in accordance with EN 100015

### Material/Finish

Sheet steel, powder-coat textured

### Supply schedule

1 Rear panel

Mounting material

### How supplied

Flat-packed kit

W	H	D	ESD	Order no.	UP
380	900			<b>00.701.010.x</b>	1 unit
380	1120			<b>00.701.011.x</b>	1 unit
380	900		•	<b>00.701.110.1</b>	1 unit
380	1120		•	<b>00.701.111.1</b>	1 unit



MET00037

## Knürr MetraMobil® Cable Management Set

### Consists of:

- Di-Strip socket strip, 4-way, without switch
- Strain relief
- Two cable reel elements

### Supply schedule

1 Cable management set  
Mounting material

### How supplied

Flat-packed kit

Order no.	UP
<b>00.701.050.1</b>	1 unit



MET00021

## Knürr MetraMobil® Castor Set

■ Load rating, 750 N per castor, Ø 125 mm

### Color

RAL 9011, graphite black

### Supply schedule

4 smooth-running castors,  
2 with brake

ESD	Order no.	UP
	<b>00.701.965.9</b>	1 unit
•	<b>00.128.975.9</b>	1 unit

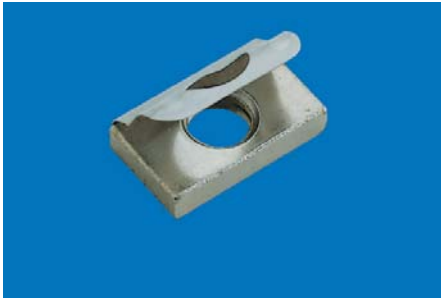

MEC00060

## Spring nuts M5 and M6

- For clipping into T-slots at any position
- For mounting chassis rails and other components

**Material**  
Steel, St 1203  
Spring band, Nirosta 4310

**Supply schedule**  
50 spring nuts

W	H	D	Model	Order no.	UP
			M6	01.350.405.9	1 unit
			M5	01.350.431.9	1 unit



MOB20013

## Universal Arm

- 3-joint with manual clamp
- With cable/hose holder

**Supply schedule**  
1 universal arm incl. adapter

W	H	D	Order no.	UP
			00.306.950.1	1 unit



MOB20083

## Antistatic Castor Set

- Load capacity – 90 kg

**Color**  
RAL 9011, graphite black

**Supply schedule**  
4 smooth-running castors  
2 with brake

Type	Color	Diameter	Order no.	UP
ESD	Black	125	00.128.975.9	1 unit

Dimensions in mm: W= Width  
H = Height  
D = Depth  
h = Installation height  
d = Useful depth  
L = Length

HU = Standard height  
unit, 1 HU = 44.45 mm  
19" = 482.6 mm,  
(ideal for 19" components  
in acc. with DIN 41494)  
UP = Unit of packaging  
kg = Weight

Conversion: 1 inch = 25,4 mm  
Replace „x“ with the number of your  
color choice

**P** = assemble to order (shipped within  
10 working days)

Caution: In case of larger orders, delivery  
times may increase.



MOB00331

## Cable routing set Mounting on the vertical extrusions

- **Material**  
Plastic
- **Color**  
RAL 7035, light gray
- **Supply schedule**  
1 cable routing set  
Mounting material

W	H	D	Order no.	UP
	500		00.101.001.9	1 unit



MOB00338

## Cable Winder For up to 5 m of cable

- **Material**  
Plastic
- **Color**  
RAL 7035 light-grey
- **Supply schedule**  
2 Cable winders  
Mounting material

W	H	D	Order no.	UP
			00.306.957.1	1 unit



MOB20099

## Isolating Transformers

**NTC:** For switch-on peak limit are NTCs in the input power circuit before the transformer.

Basis of EC Declaration of Conformity in acc. with Directive 93/42 EEC, Annex I:  
EN60601-1, EN60601-1-1  
EN60601-1-1-2 (EMC)  
EN14971

- **Supply schedule**  
1 isolating transformer  
1 mains cable, 2.5 m  
with protective contact plug

- **How supplied**  
Flat-packed kit

- **Note**  
Additional versions available on request

W	H	D	Switch-on current limiter	Type	Power (W)	Order no.	UP
286	110	312	NTC	IMed 2000E	2000	00.100.842.9	1 unit



MOB20100

## Leakage Detector Set

- Monitoring and alert unit for secondary isolation resistance
- For use in combination with isolating transformers IMed senes
- Precise warning of isolating failures

**Technical data**  
230 VAC, IP 40

In case of defect the ELG signals an optical and acoustic warning. The resistance is monitored. If the minimum level of 50 kOhm is short fallen, an optical (LED) and acoustic (Beeper) signal is triggered. The ELG is directly connected to one of the output plugs of the IMED transformers. Its function is solely to signal isolating failures.

**The ELG is exclusively approved in combination with the Noratel IMED transformers.**

L	W	H	Order no.	UP
192	32	56	00.100.841.9	1 unit



MOB00042

## Gas Bottle Holder

Bottle holder for 5 L or 10 L bottles up to max. Ø 150 mm

**Finish**  
RAL 7035 light-grey

**Supply schedule**  
1 Bottle holder  
1 Retaining belt  
Mounting material

W	H	D	Order no.	UP
			00.100.075.1	1 unit



MOB00232

## Standard Rail

Length, 460 mm

**Material**  
High-grade steel 25x10 mm

**Supply schedule**  
1 Standard rail  
Mounting material

W	H	D	Model	Order no.	UP
460	25	10	Knürr DacoMobile®	00.128.016.1	1 unit
460	25	10	Knürr EliMobil®	00.306.940.1	1 unit



MOB20053

## Side Shelf

For Knürr DacoMobile® and Knürr EliMobil®

**Material**  
Laminated 3-layer particle board  
Folding brackets: sheet steel  
Finish: RAL 7035 light grey

**Delivery Schedule**  
1 side shelf  
1 set of folding brackets  
Mounting hardware

W	D	Order no.	UP
300	400	00.101.250.1	1 unit

Dimensions in mm: W= Width  
H = Height  
D = Depth  
h = Installation height  
d = Useful depth  
L = Length

HU = Standard height unit, 1 HU = 44.45 mm  
19"= 482.6 mm, (ideal for 19" components in acc. with DIN 41494)  
UP = Unit of packaging  
kg = Weight

Conversion: 1 inch = 25,4 mm  
Replace „x“ with the number of your color choice

**P** = assemble to order (shipped within 10 working days)

Caution: In case of larger orders, delivery times may increase.



MOB00339

## IV-Pole

- Can only be used in combination with standard rails, BN 00.128.016.1 or B/N 00.705.068.x SynergyCart® holder for infusion stands
- 4 Hooks
- Chrome-plated
- Height adjustable
- Width, approx. 110 cm

**Load rating**  
2 kg per hook

**Supply schedule**  
1 Serum holder including mounting (without standard rails)

W	H	D	Order no.	UP
			00.306.955.0	1 unit



MOB00337

## Hook-On Block For holding test pins

**Note**  
Only for Knürr DacoMobile® and Knürr EliMobil®

**Material**  
Plastic

**Color**  
RAL 9011, graphite black

**Supply schedule**  
1 hook-on block  
Mounting material

W	H	D	Order no.	UP
			00.701.090.9	1 unit



## Multi-Functional Extrusions for Flat Screen Supports

- For mounting between the Knürr Mobile vertical extrusions
- Sturdy and stable Knürr TFT Adapter connection

**Note**  
TFT adapters are not included in the supply schedule, please order separately

**Material**  
- Extruded aluminum extrusions  
- Sheet steel mounting plates

**Finish**  
Metal parts – powder-coated, RAL 9006, white aluminum

**How supplied**  
Flat-packed kit

**Supply schedule**  
2 Funktional rails  
Mounting material

W	Model	Order no.	UP
496	Knürr DacoMobile®	00.101.007.9	1 unit
596	Knürr DacoMobile®	00.101.008.9	1 unit
500	Knürr MetraMobil®	00.701.055.9	1 unit
450	Knürr EliMobil®	00.306.980.9	1 unit
550	Knürr EliMobil®	00.306.981.9	1 unit

Right from the very beginning

# Project Management

Take advantage of our expert knowledge, which we have been gathering for decades in numerous customer projects in various industries.

Our **project managers** are your contact partners. They are the interface to you and are responsible for the project planning in accordance with your individual requirements profile. Depending on the complexity of the task at hand, they put together a **professional team** of specialists from the most diverse disciplines.

Numerous factors are incorporated – from the creation of a list of functional specifications, budgeting and deadline planning, through to special design specifications and technical integration, right on through to compliance with standards and guidelines.

During the **product design** phase, industrial designers and technicians work closely together to harmonize form and function. With the assistance of 3D-CAD models, you check the result and can integrate your suggestions at any time.

**Prototyping** is also firmly in the hands of experts who are hard at work incorporating your requests and suggestions into an initial specific product.





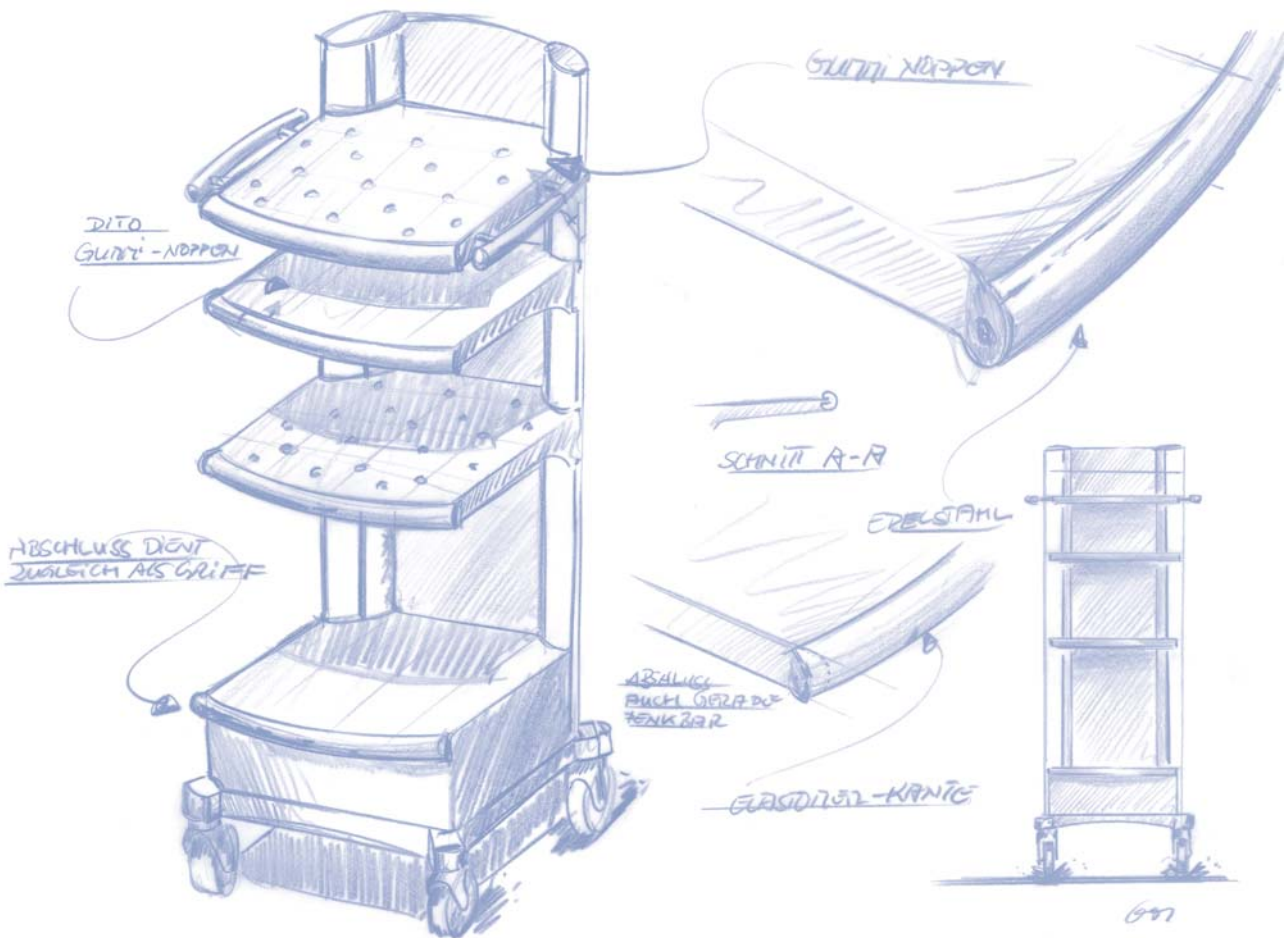

## Design and function

# Design

Using the most modern CAD applications, we design your products, which set new standards in terms of technology and aesthetics. On the basis of the planned details, 3-D views, design studies and volume models emerge, which represent the most realistic state of development progress and enable modifications in line with your wishes at absolutely any time.

Your company-own corporate design is also integrated with our proposals for materials and color. Ultimately we ensure a smooth technical and technological integration while complying with UL, CSA, VDE or TÜV/GS standards. Only when these stages have been fully completed, can the first prototype be produced.



Exemplary results

# Production and logistics

After production release by the customer our sophisticated **logistics concepts** go into operation. Customized planning procedures are integrated and smoothly implemented in our **Supply Chain Management**.

We produce application-specific equipment trolleys in ultra-modern **industrial production procedures**.

And in the production phase our employees guarantee the best possible end product with their long years of experience in parts production, packaging and shipping, supported by our integrated **quality assurance procedures**.

This also includes extensive **packaging expertise**, equipped for global shipping and the toughest environmental conditions.



OEM

# Individual solutions

Our standard modules mean the possibilities for unique originals are practically unlimited.

**Help us with your requests!** Ask us about your original and stand out on the market with your equipment trolley with customized design, harmonized with your company image (CI/CD).

Our expert **Design and Technology** Team will be happy to optimally and specifically meet all customer-specific requirements – assuming the appropriate batch sizes.

“Avail of our long years of **experience**, which we use to ergonomically, technically and optimally incorporate our mature and flexibly adjusted product platforms and components into your **individual solution**.”



## Ergonomically designed products and solutions from a single source

**Emerson Network Power**, a business of **Emerson** (NYSE:EMR), delivers software, hardware and services that maximize availability, capacity and efficiency for data centers, healthcare and industrial facilities.

Learn more about Emerson Network Power products and services at [www.EmersonNetworkPower.eu](http://www.EmersonNetworkPower.eu)

**Knürr Technical Furniture** as business unit manufactures and develops workstations for electronics labs and mobile equipment carriers for healthcare and automotive industries. Furthermore Knürr is the specialist for height adjustable control room workstations.

Learn more about Knürr Technical Furniture products and services at [www.technical-furniture.com](http://www.technical-furniture.com)

**Emerson Network Power**  
Global Headquarters  
1050 Dearborn Drive  
P.O. Box 29186  
Columbus, OH 43229, USA  
T +1 614 8880246

**Knürr Technical Furniture GmbH**  
Mariakirchener Straße 38  
94424 Arnstorf  
Germany  
T +49 8723 28 0  
F +49 8723 28 138  
[furniture@knuerr.com](mailto:furniture@knuerr.com)  
[www.technical-furniture.com](http://www.technical-furniture.com)

While every precaution has been taken to ensure accuracy and completeness herein, Emerson assumes no responsibility, and disclaims all liability, for damages resulting from use of this information or for any errors or omissions. Specifications subject to change without notice.

Knürr and Knürr logo, Emerson, Consider it Solved, Emerson Network Power and the Emerson Network Power logo are trademarks and service marks of Emerson Electric Co. or one of its affiliated companies. ©2014 Emerson Electric Co. All rights reserved.